

Section : Body
Electrical
Ref. No. : BE-0025
Date : Jul., 2000
Page : 1 of 2

Area Application : Europe, Others(Saudi Arabia)

Model Name : LAND CRUISER, LAND CRUISER PRADO

Model Code : RZJ95, KDJ90, 95

Subject : ELECTRICAL WIRING DIAGRAM

This Service Bulletin is to inform you of the Electrical Wiring Diagram for the following systems due to the additions of the model equipped with 1KD-FTV engine and the engine immobiliser system for 3RZ-FE engine.

System	Location	
	LHD	RHD
Air Conditioner (Automatic 1KD-FTV)	49-4	47-4
Center Differential Lock (1KD-FTV w/VSC)	46-2	44-2
Charging (1KD-FTV)	41-3	39-3
Combination Meter (1KD-FTV)	48-2	46-2
Condenser Fan (Automatic 1KD-FTV)	49-2	47-2
Cruise Control (1KD-FTV)	42-10	40-10
ECT and A/T Indicator (1KD-FTV)	47-2	45-2
Engine Control (3RZ-FE w/Engine Immobiliser)	40-2	---
Engine Control (1KD-FTV)	42-2	40-2
Engine Immobiliser System (1KD-FTV)	42-12	40-12
Glow Plug (1KD-FTV)	42-1	40-1
Fuel Heater (1KD-FTV)	42-2	40-2
Illumination (1KD-FTV)	43-2	41-2
SRS (1KD-FTV)	44-2	42-2
Starting (1KD-FTV)	41-2	39-2
Viscous Heater (1KD-FTV)	46-3	44-3
VSC (1KD-FTV)	45-2	43-2

The attached pages will be applied to the following manuals.

Pub. No.	Publication Name
EWD269F	LAND CRUISER / LAND CRUISER PLADO Electrical Wiring Diagram
EWD340F	LAND CRUISER / LAND CRUISER PLADO Electrical Wiring Diagram Supplement
EWD376F	LAND CRUISER / LAND CRUISER PLADO Electrical Wiring Diagram Supplement

Production Effective :

Frame No.	Production Date
---	From August, 2000

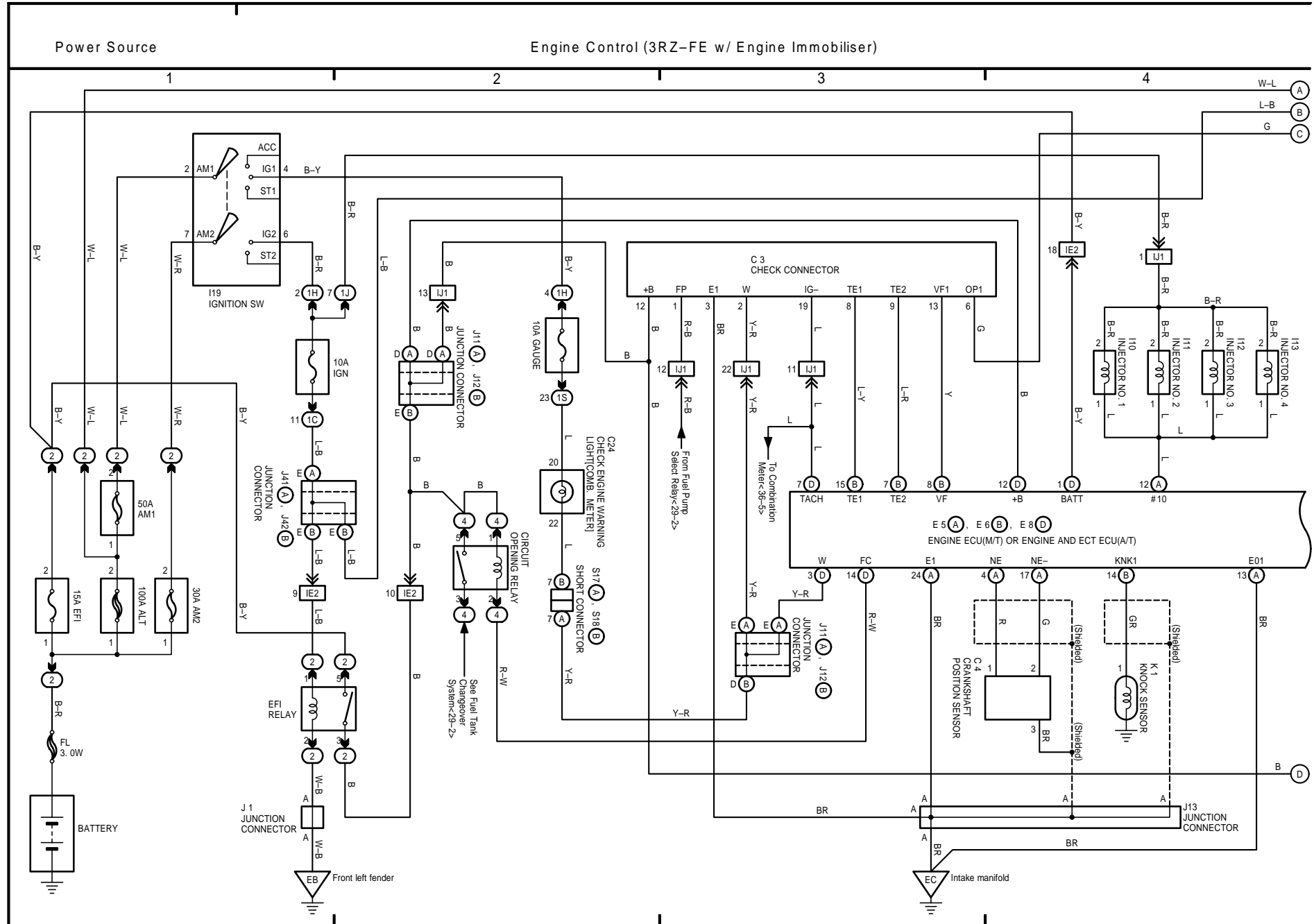

40 LAND CRUISER / LAND CRUISER PRADO (LHD) (Cont' d)

Engine Control (3RZ-FE w/ Engine Immobiliser)

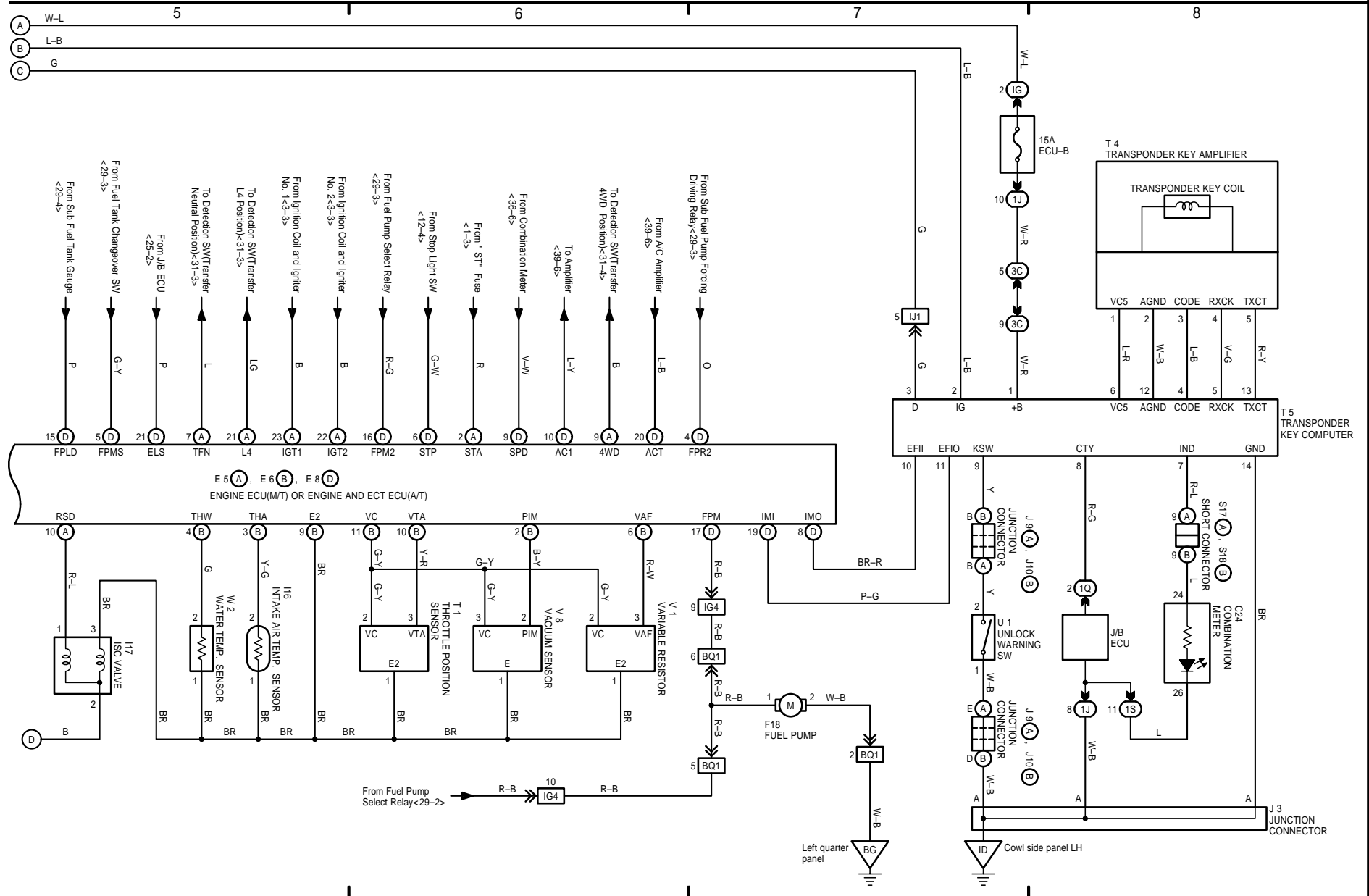

41 LAND CRUISER / LAND CRUISER PRADO (LHD)

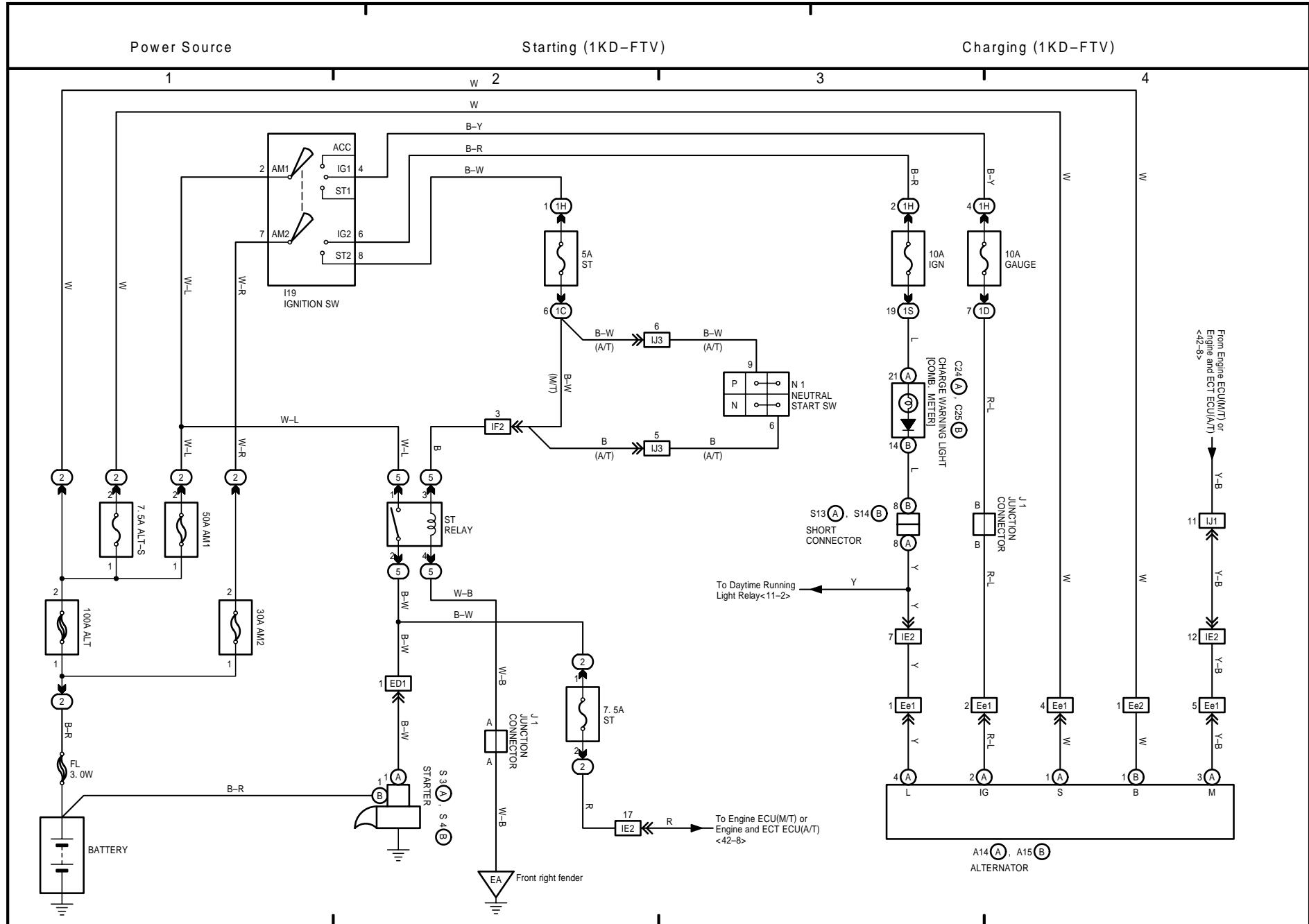

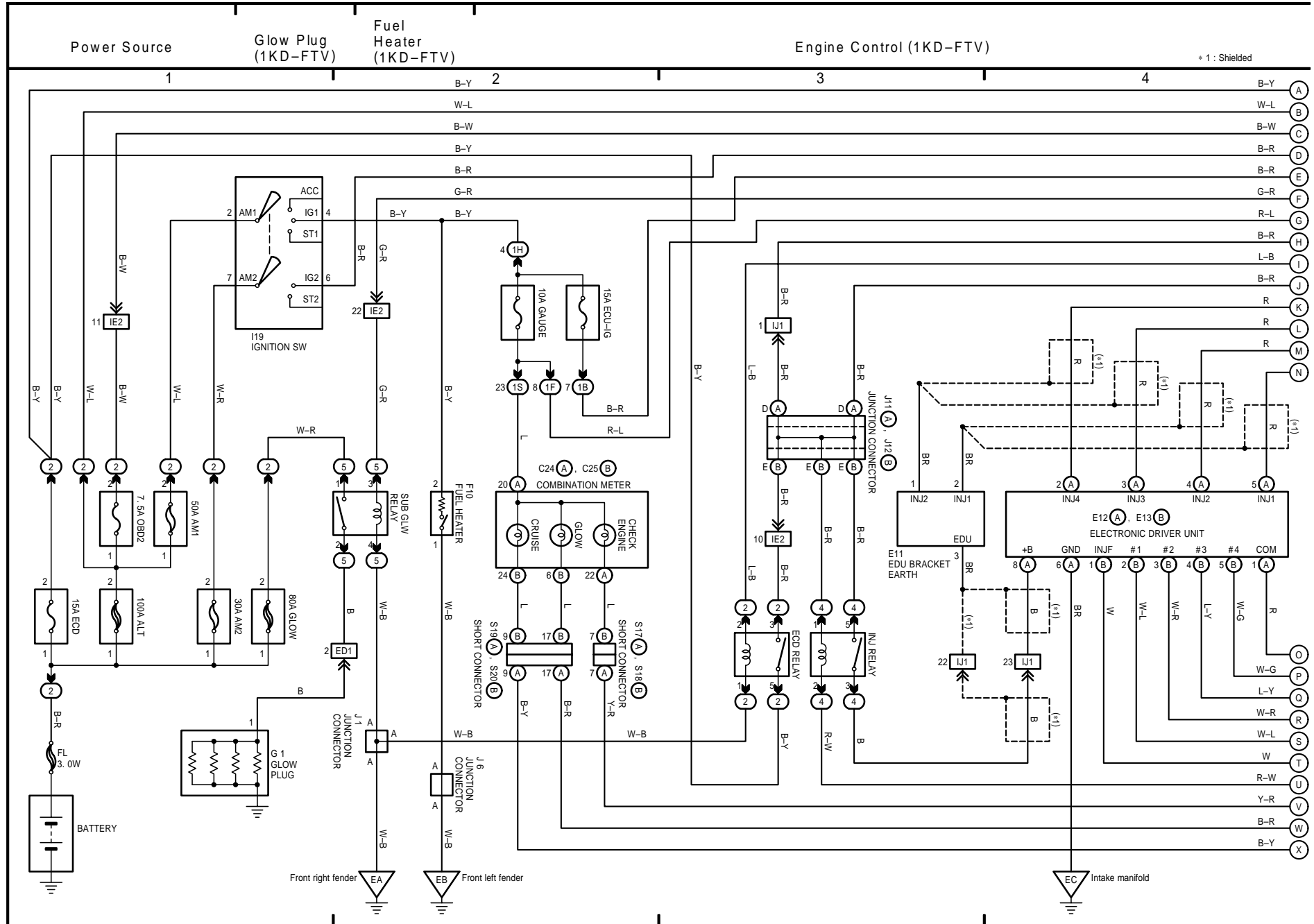

43 LAND CRUISER / LAND CRUISER PRADO (LHD)

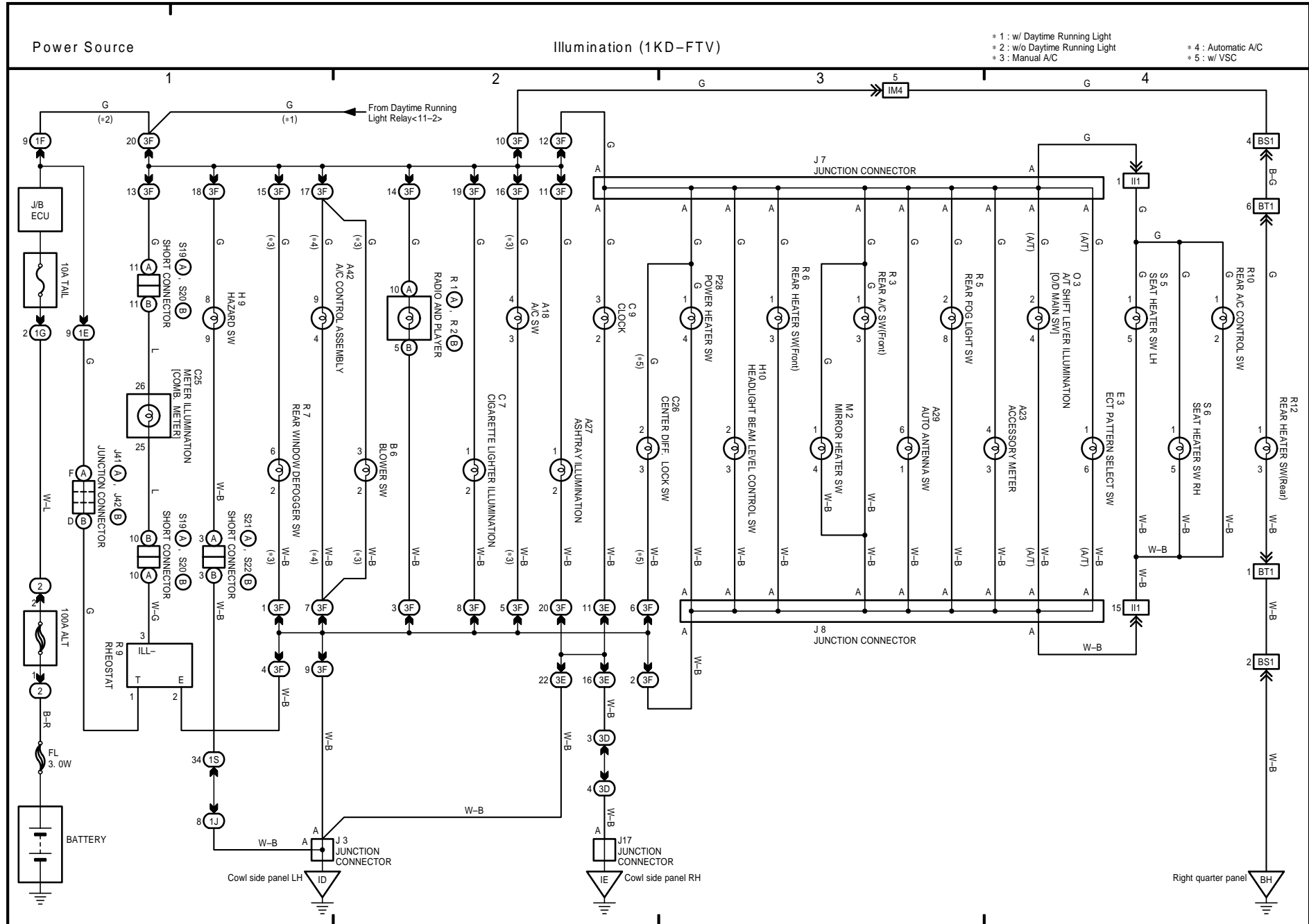

45 LAND CRUISER / LAND CRUISER PRADO (LHD) (Cont' d)

VSC (1KD-FTV)

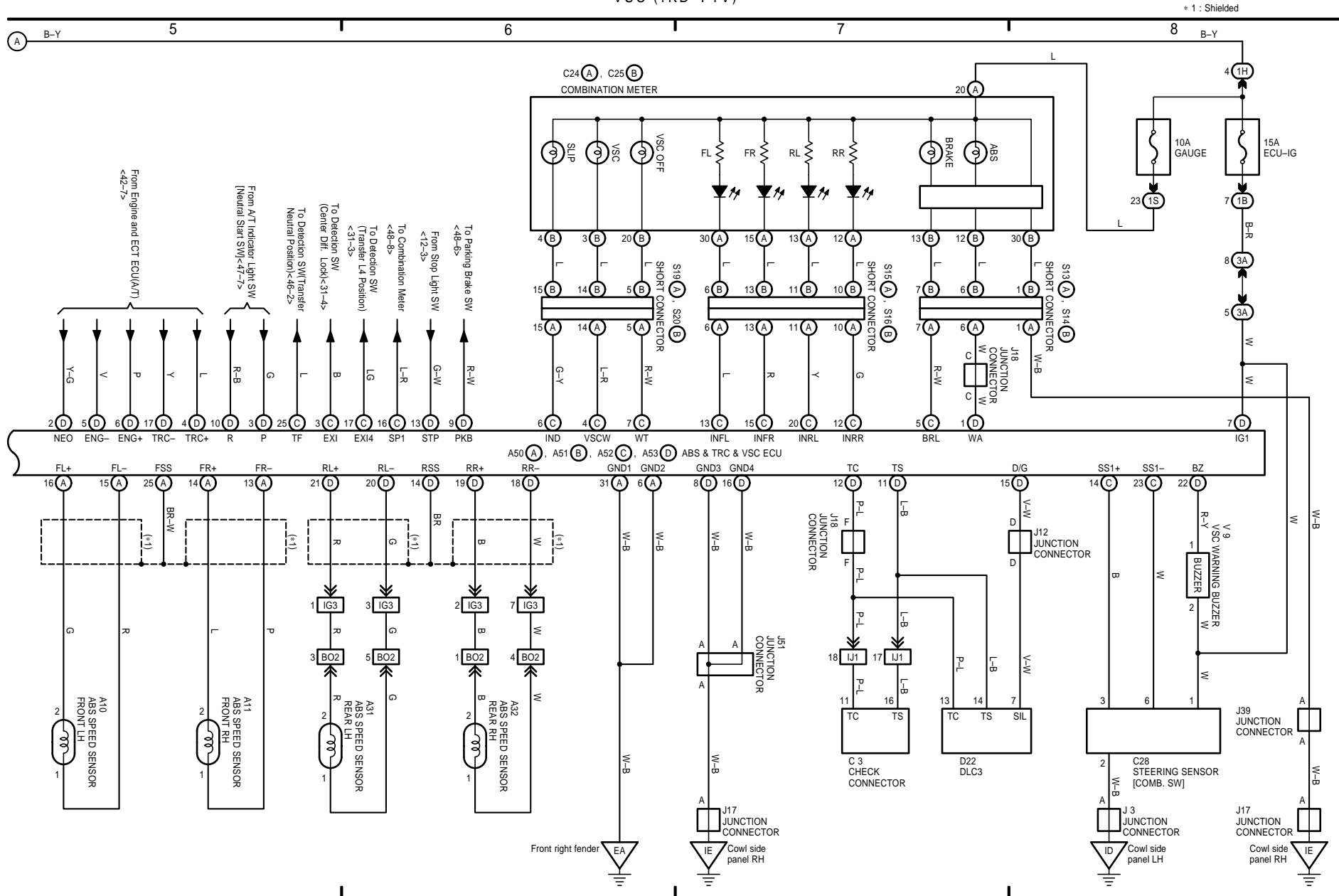

46 LAND CRUISER / LAND CRUISER PRADO (LHD)

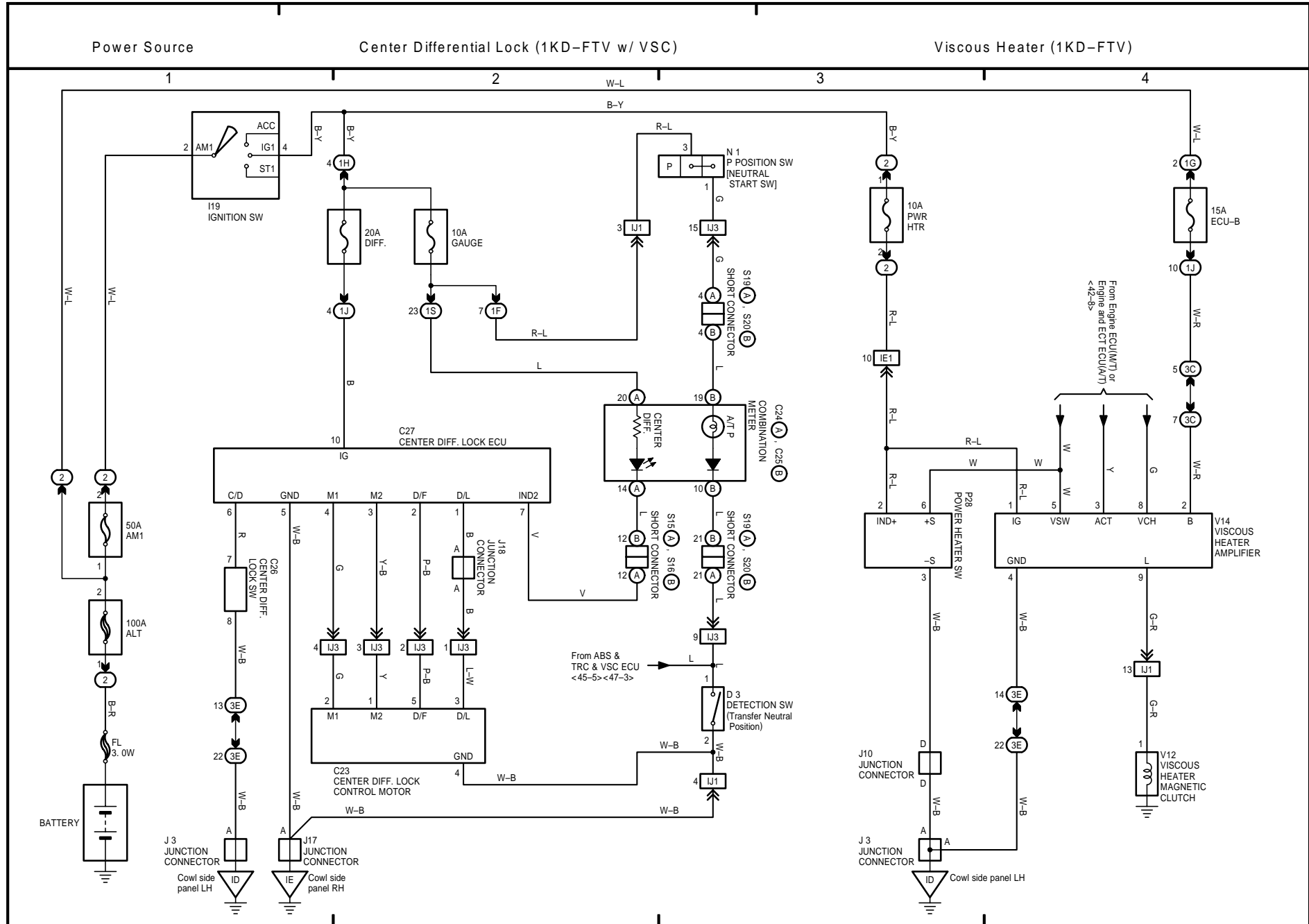

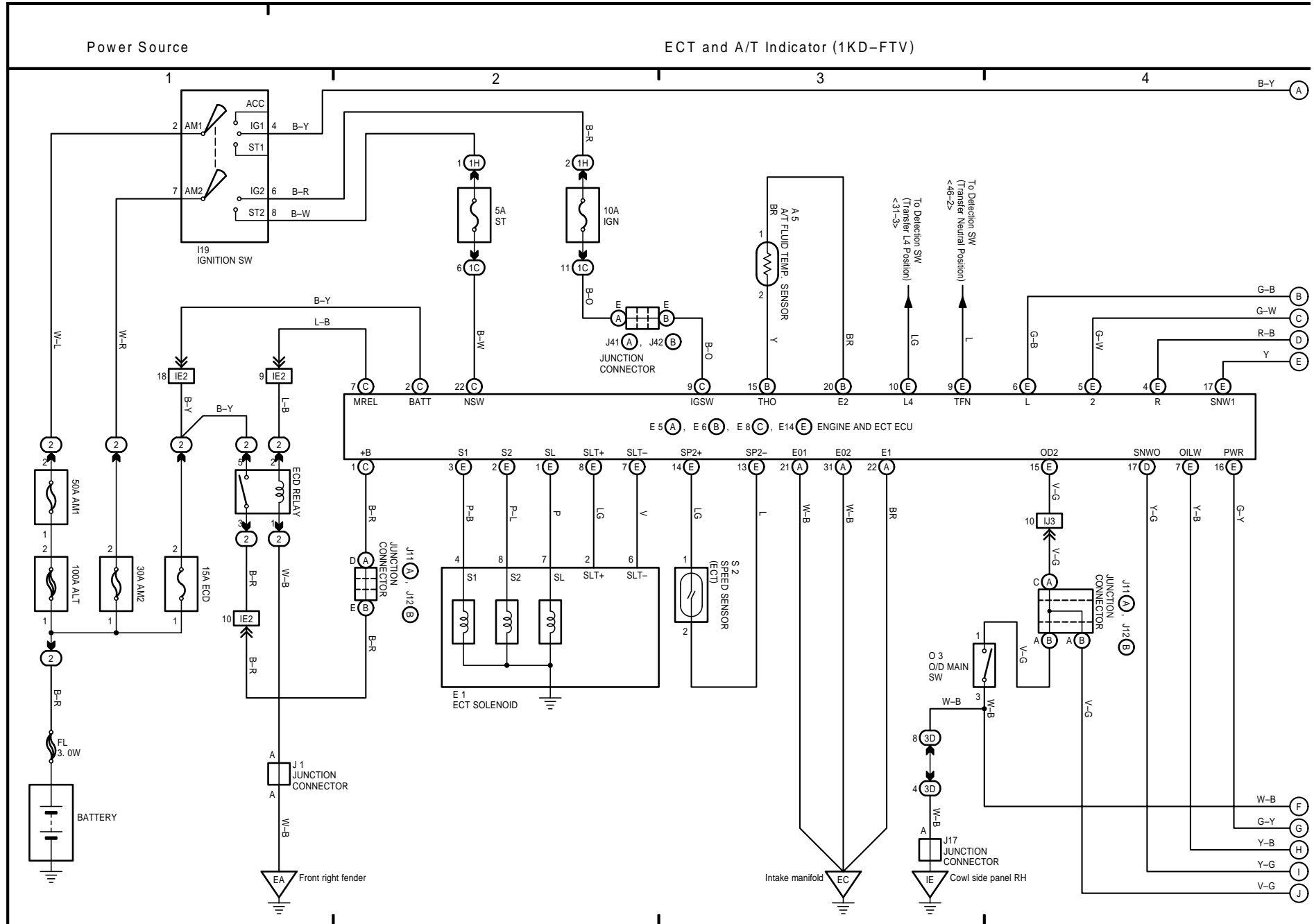

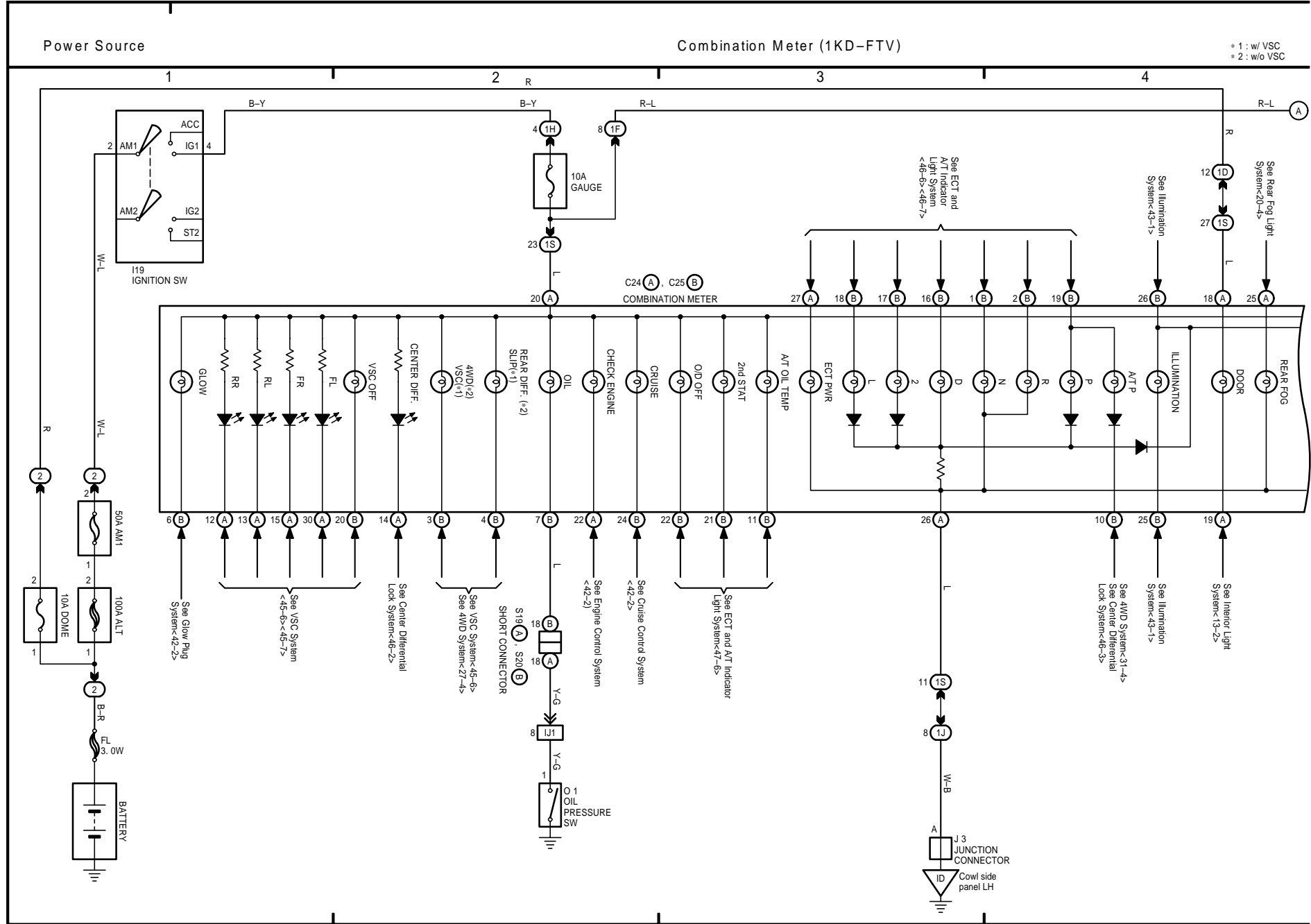

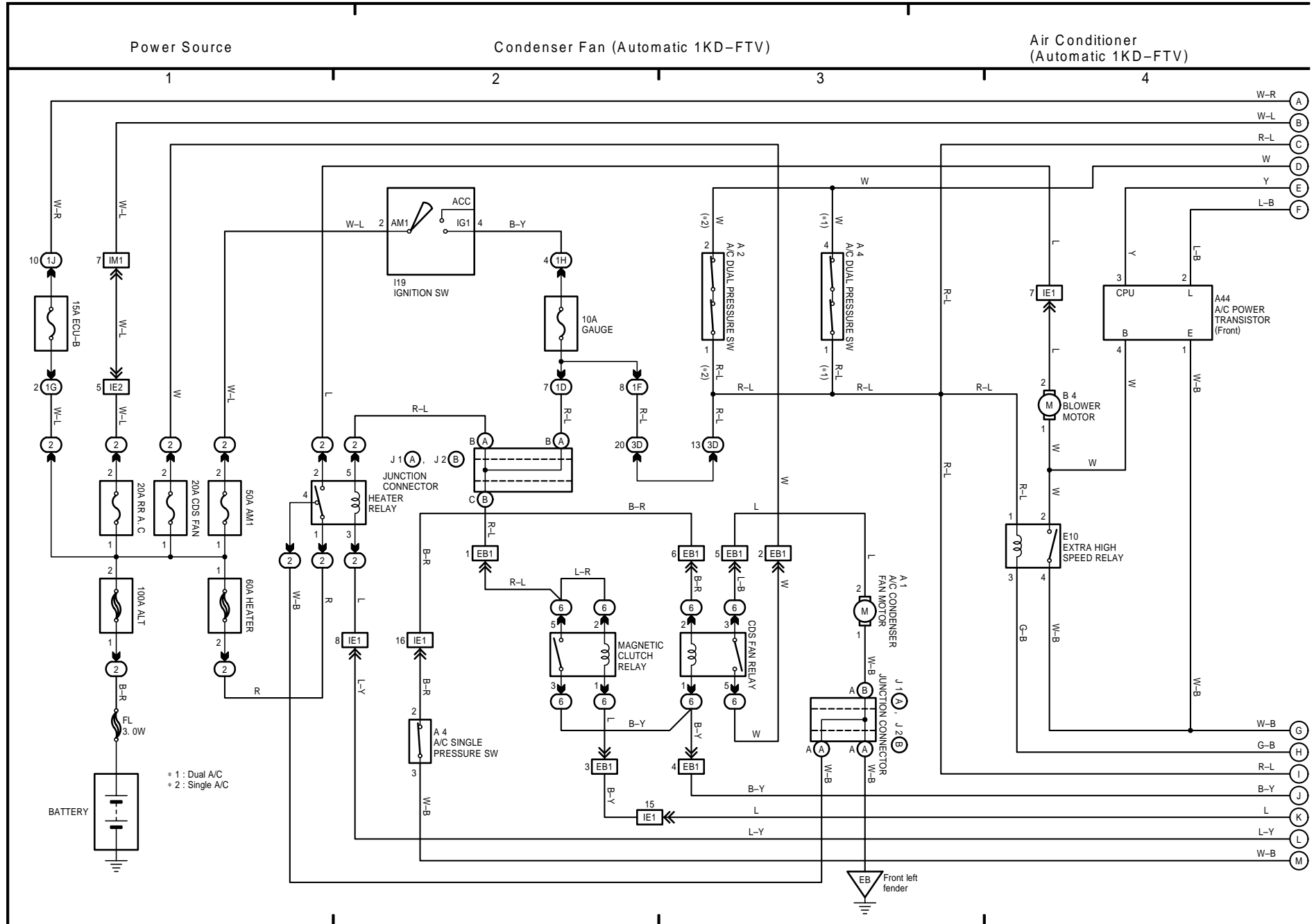

Air Conditioner (Automatic 1KD-FTV)

* 3 : w/ ABS or w/ VSC

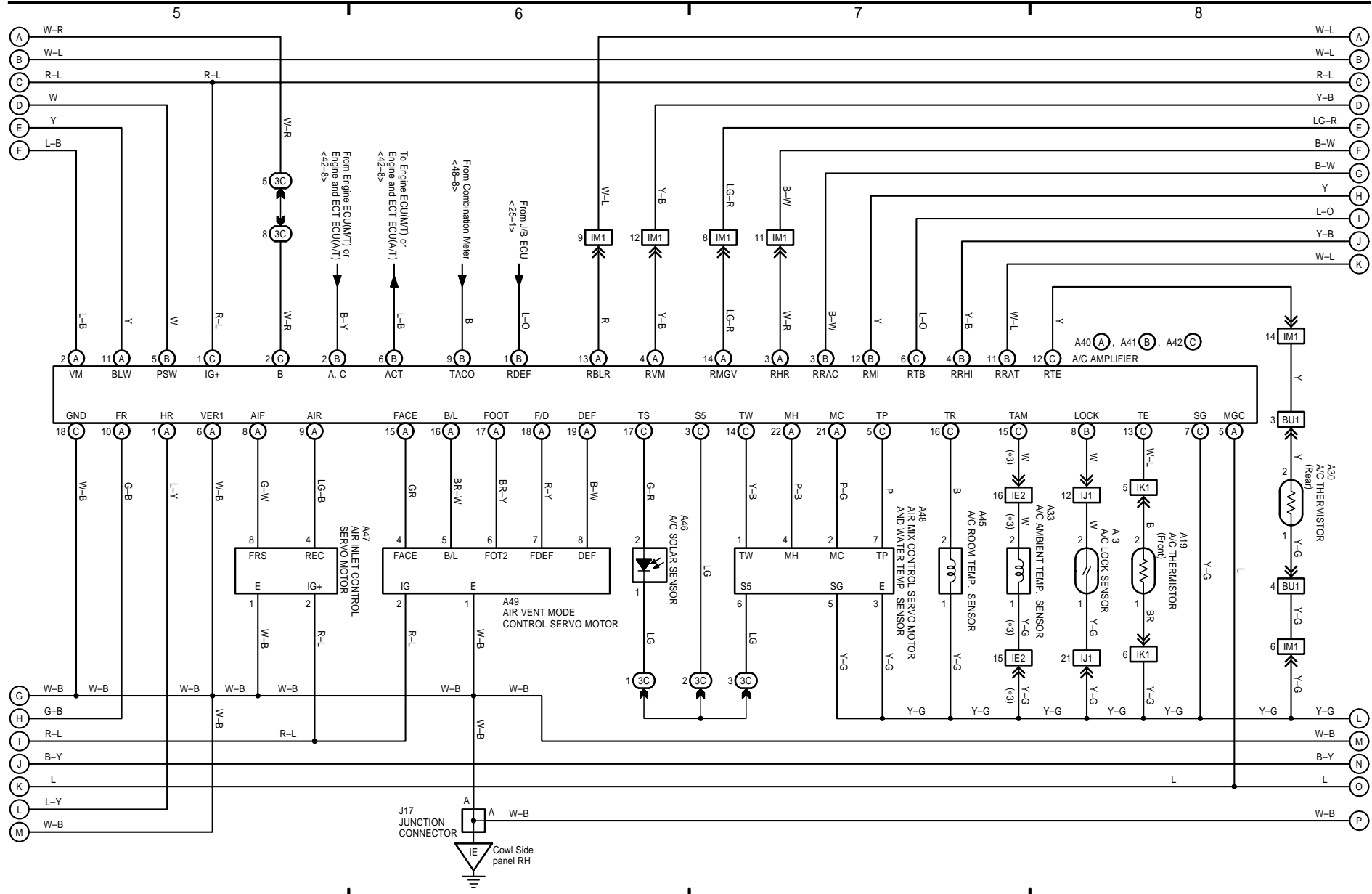

Air Conditioner (Automatic 1KD-FTV)

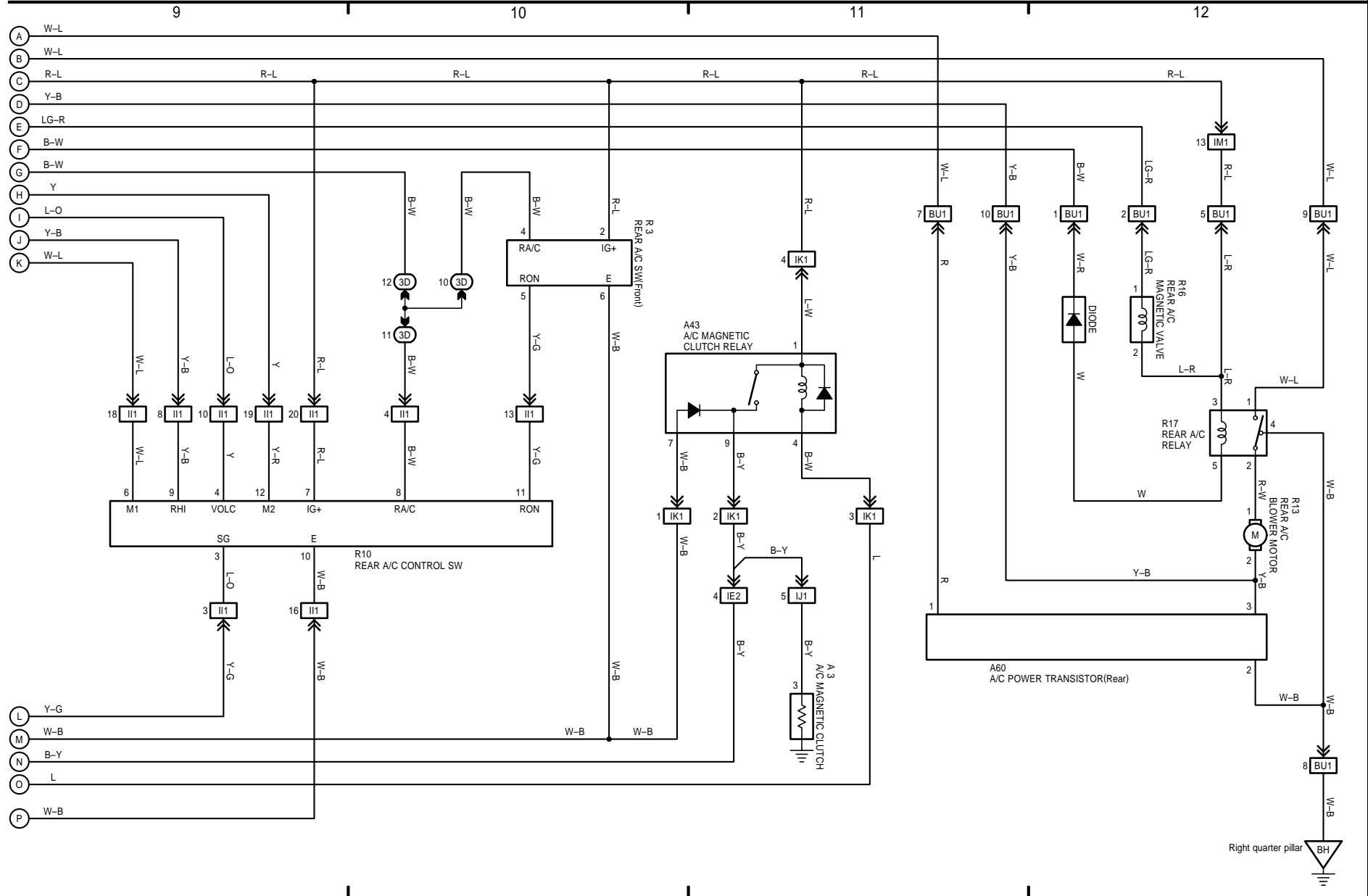

39 LAND CRUISER / LAND CRUISER PRADO (RHD)

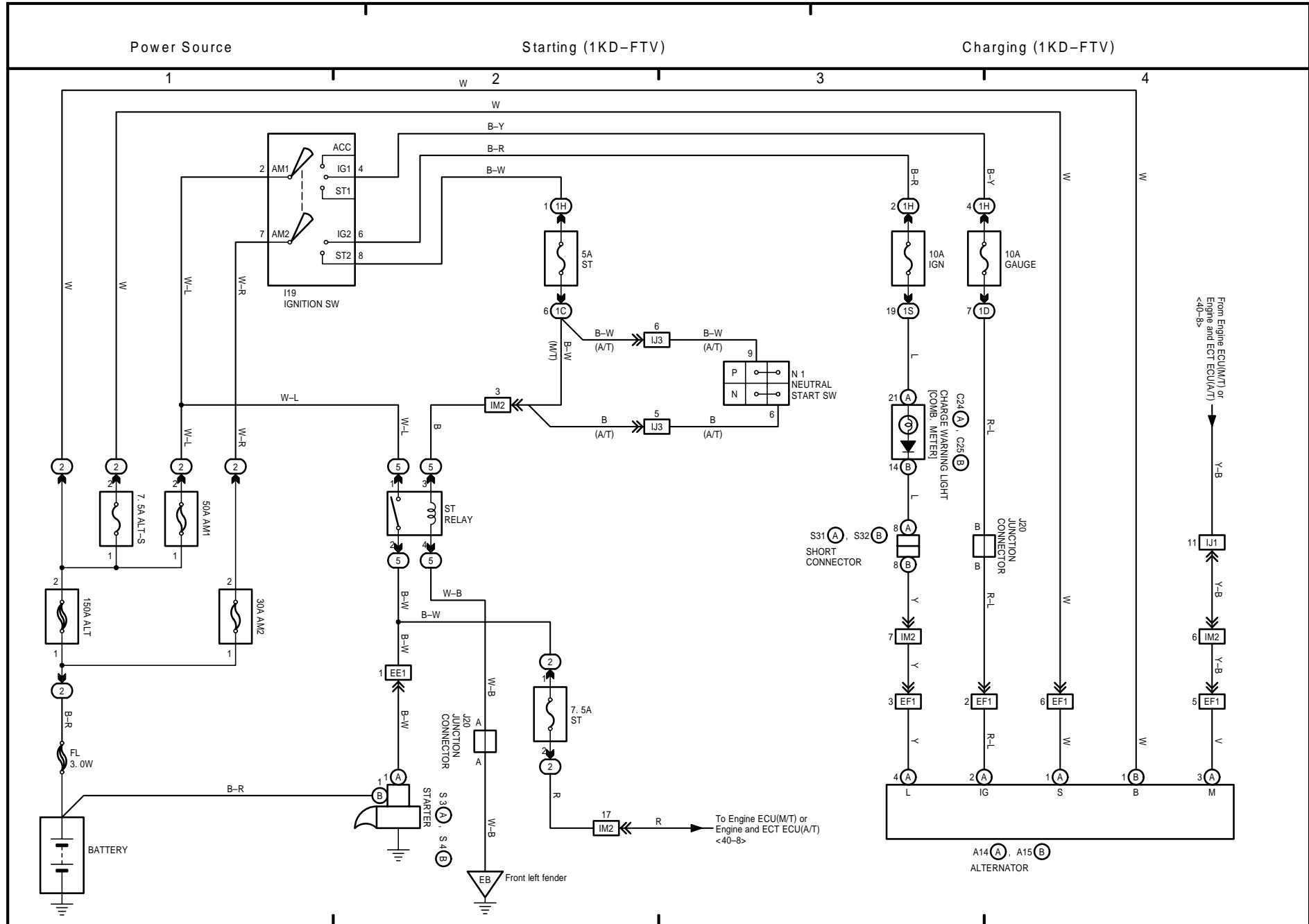

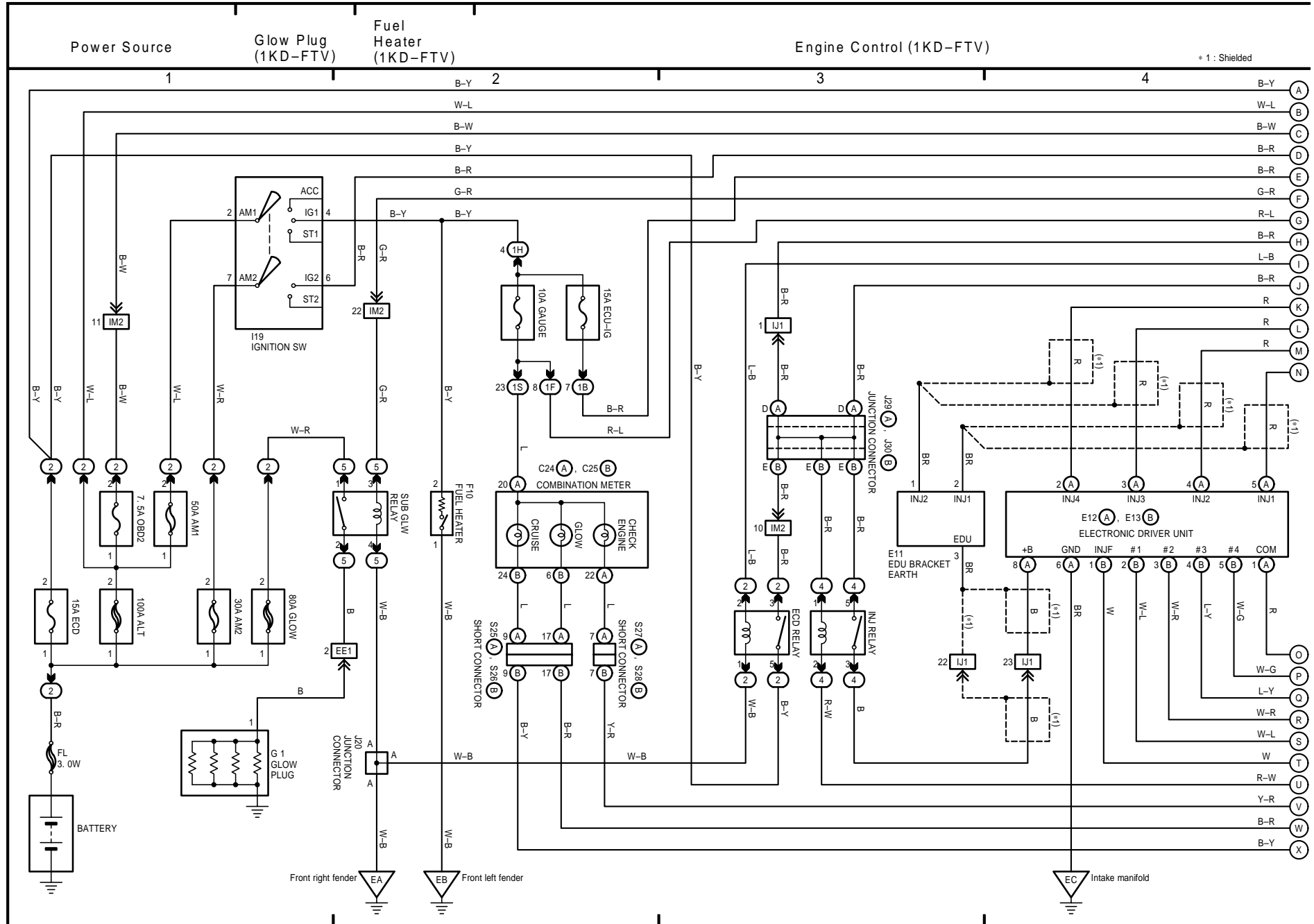

Engine Control (1KD-FTV)

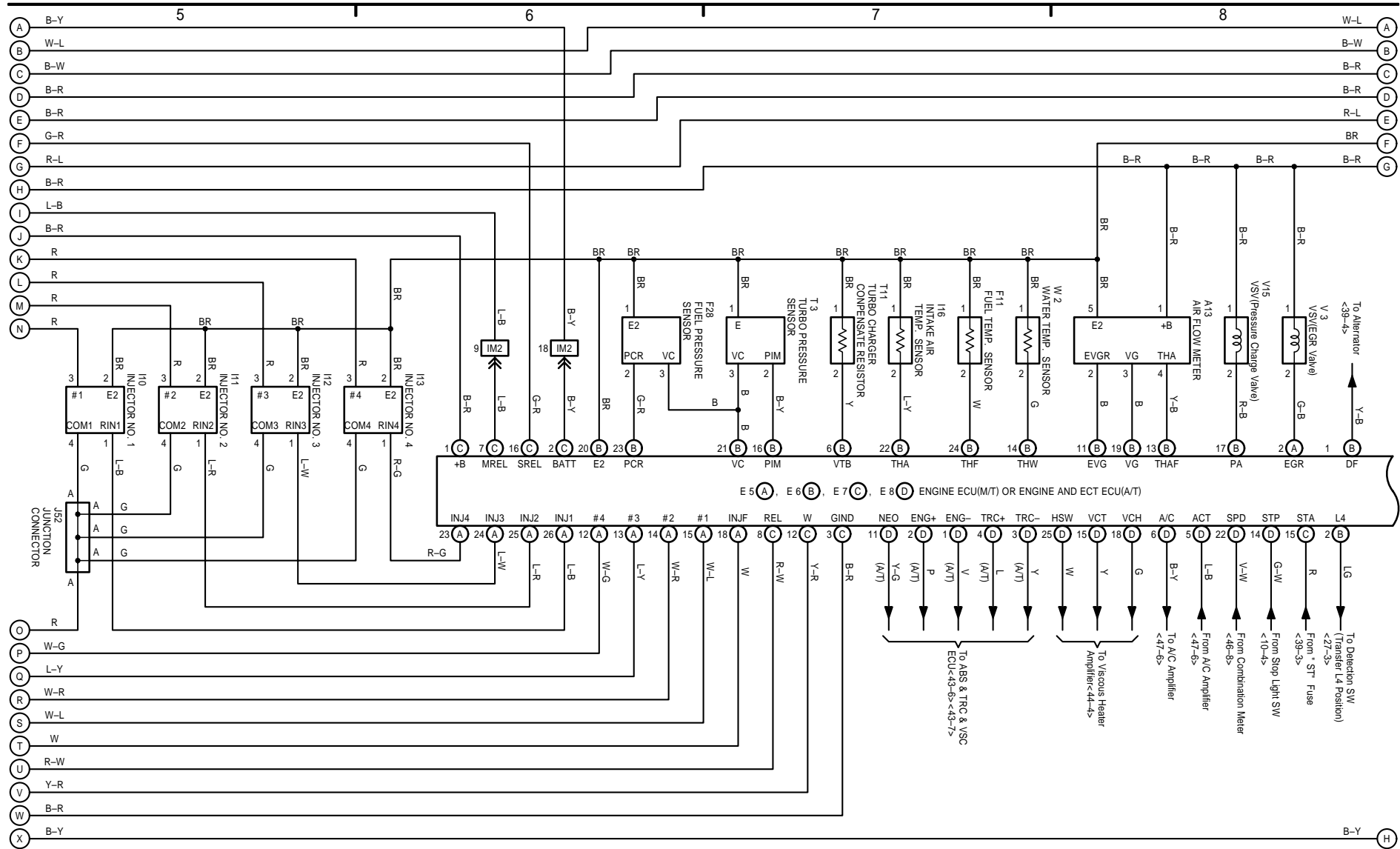

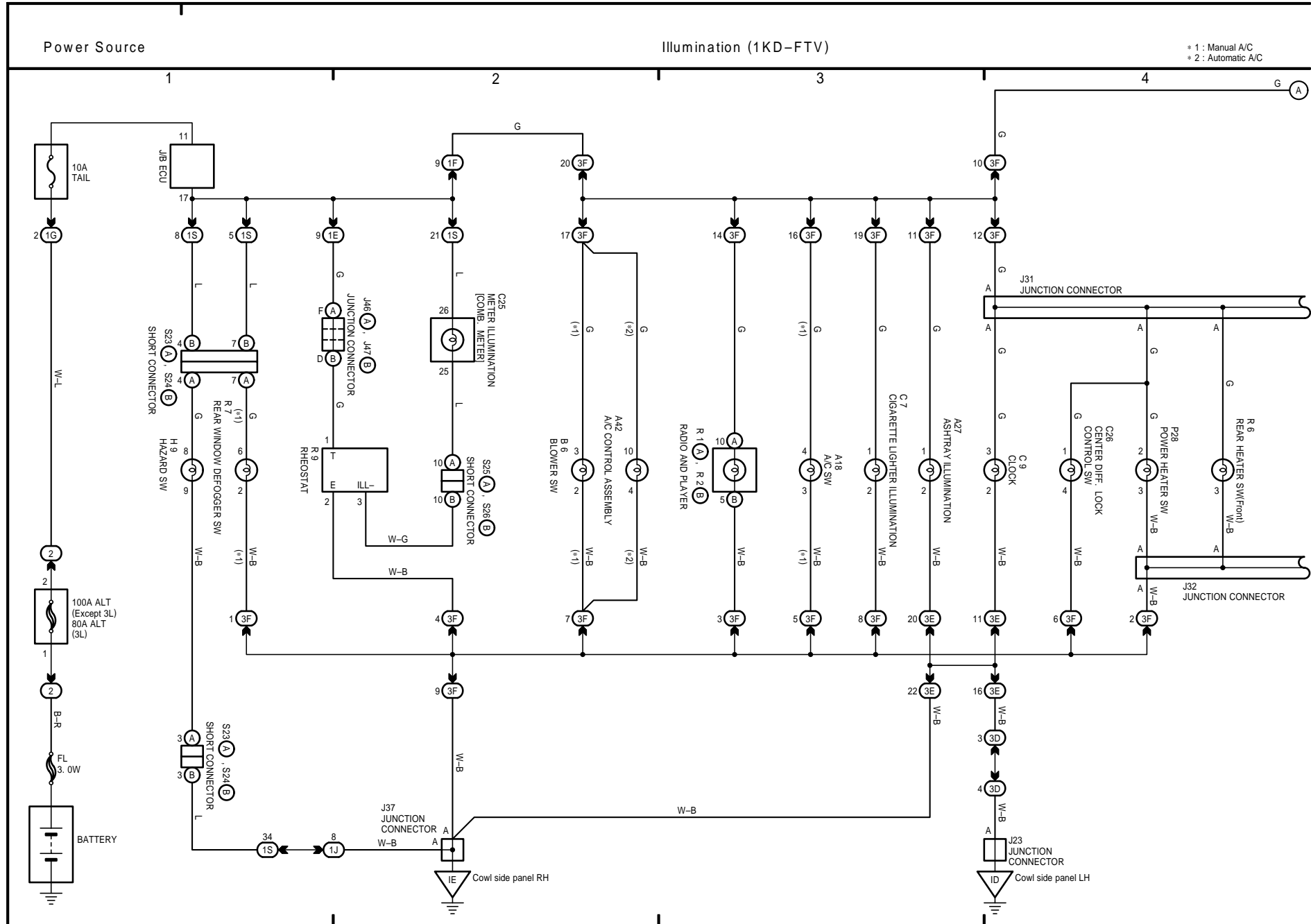

41 LAND CRUISER / LAND CRUISER PRADO (RHD) (Cont' d)

Illumination (1KD-FTV)

* 3 : w/ Rear A/C
 * 4 : w/o Rear A/C

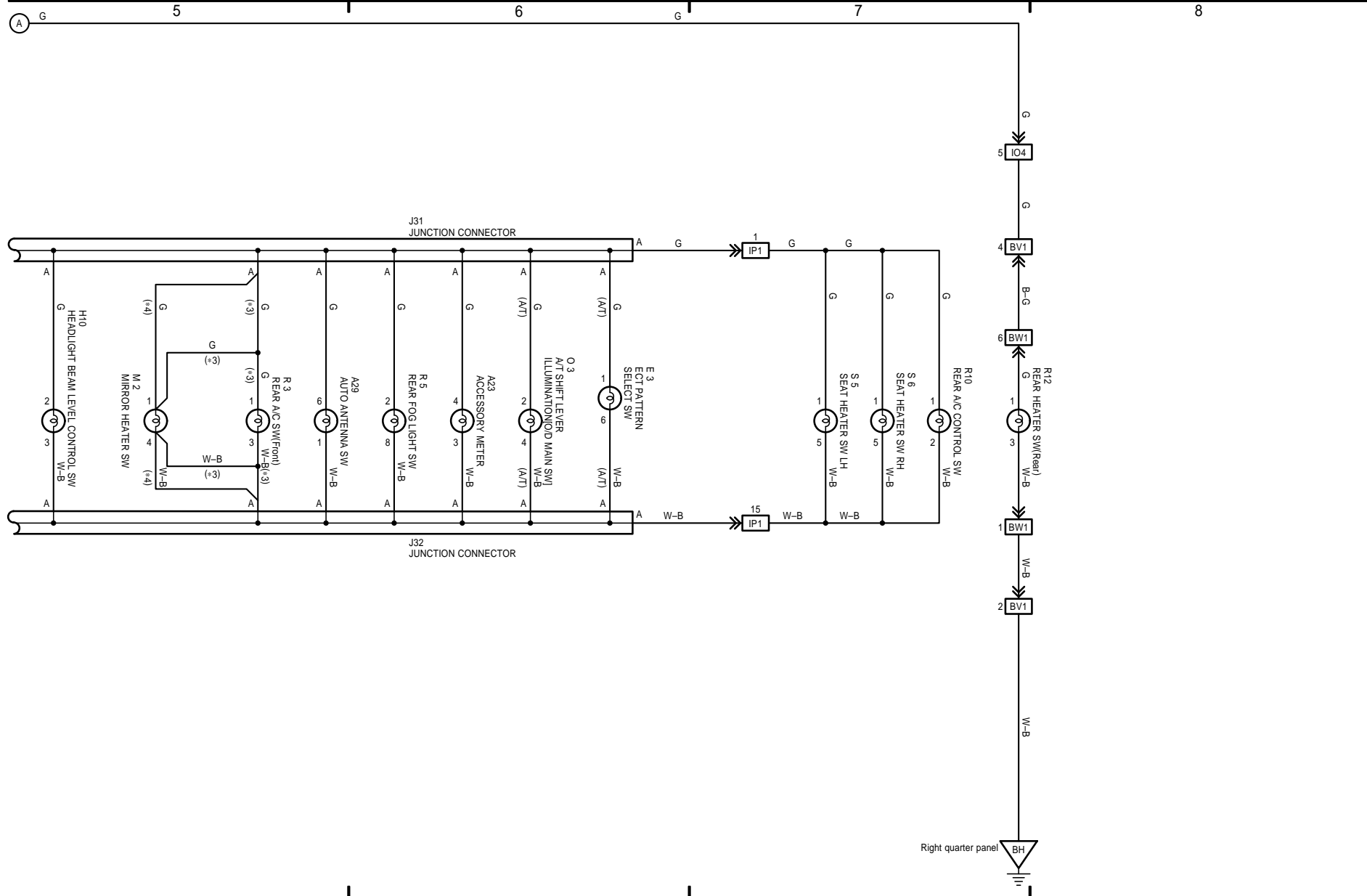

42 LAND CRUISER / LAND CRUISER PRADO (RHD)

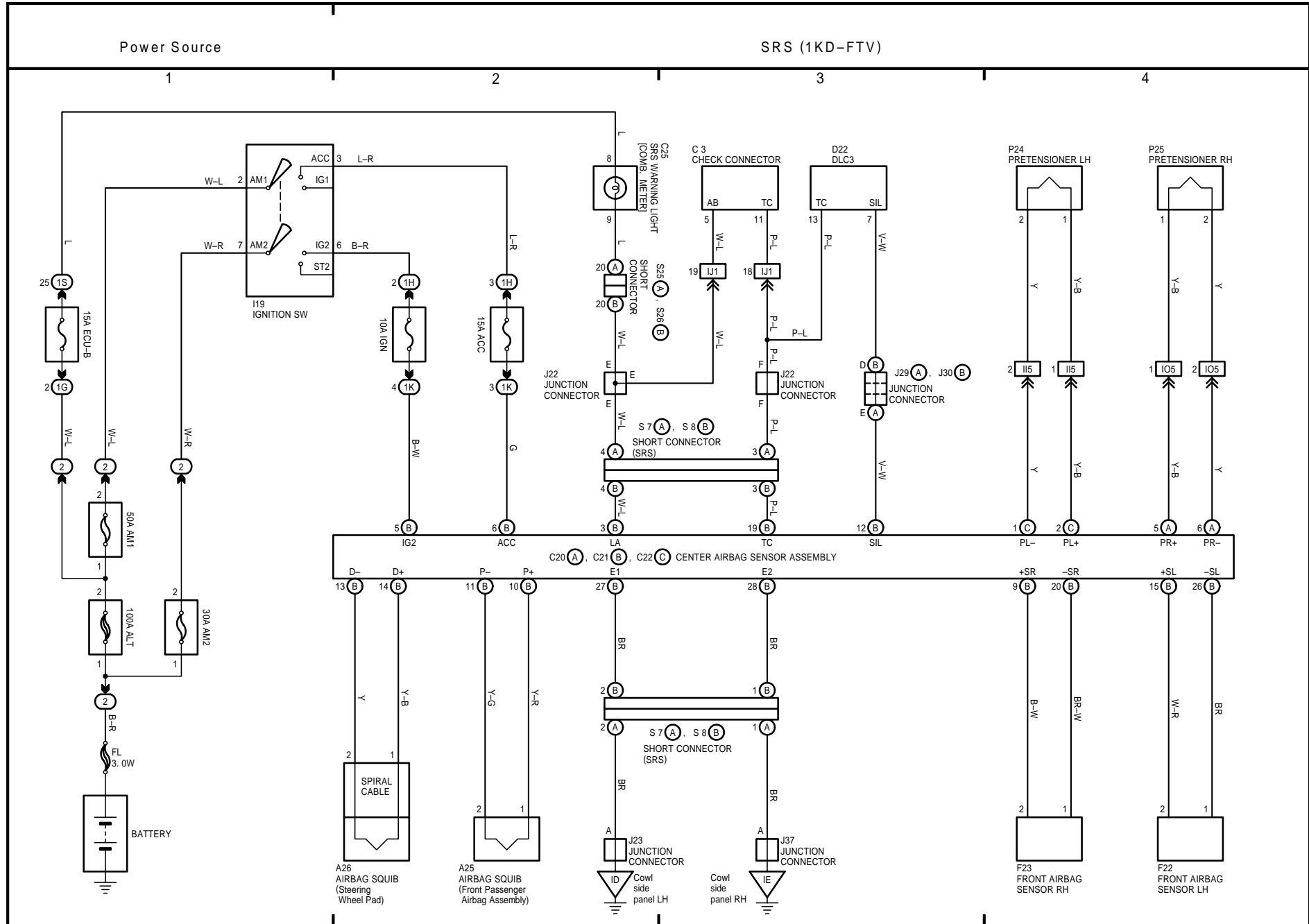

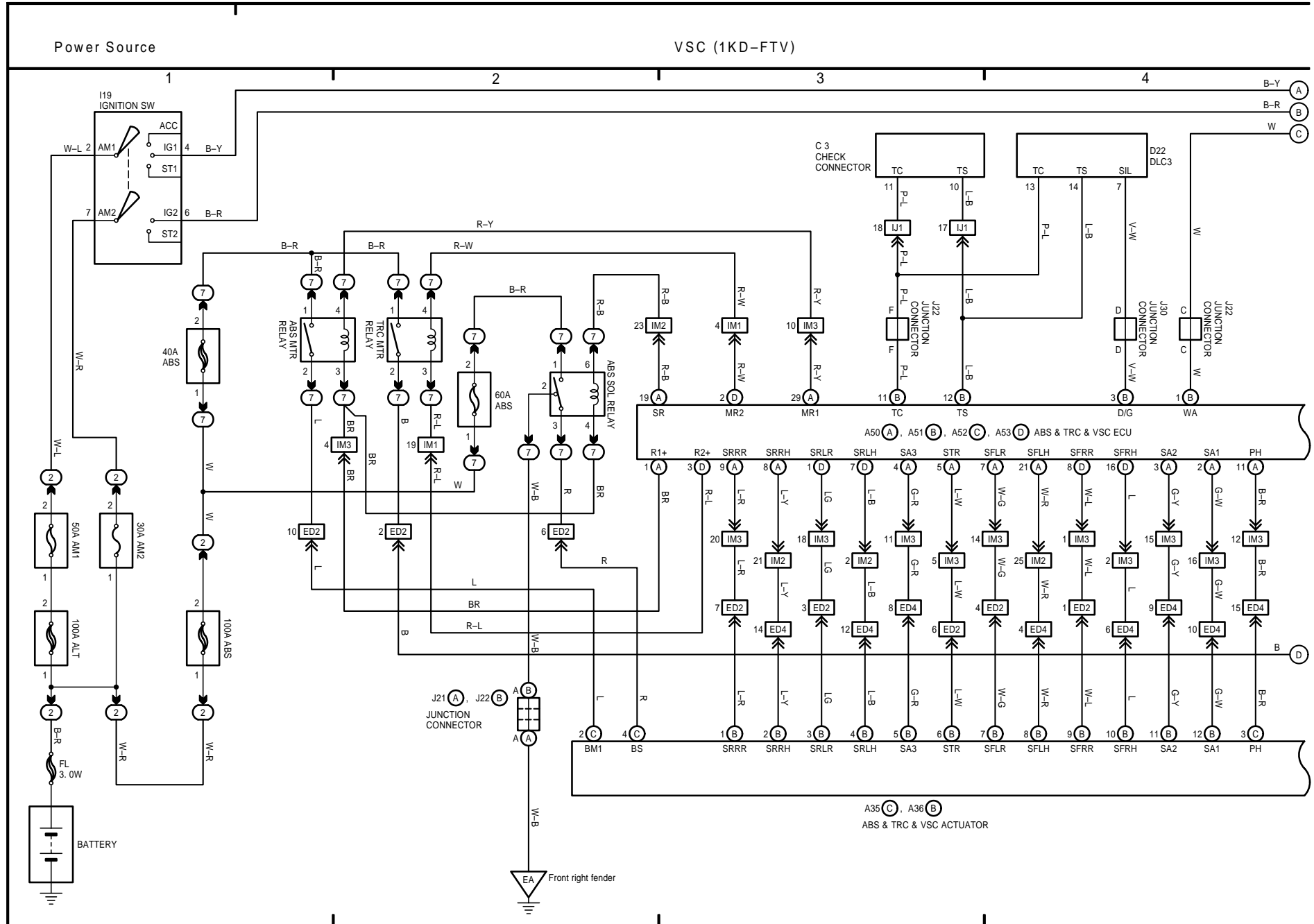

VSC (1KD-FTV)

* 1 : Shielded

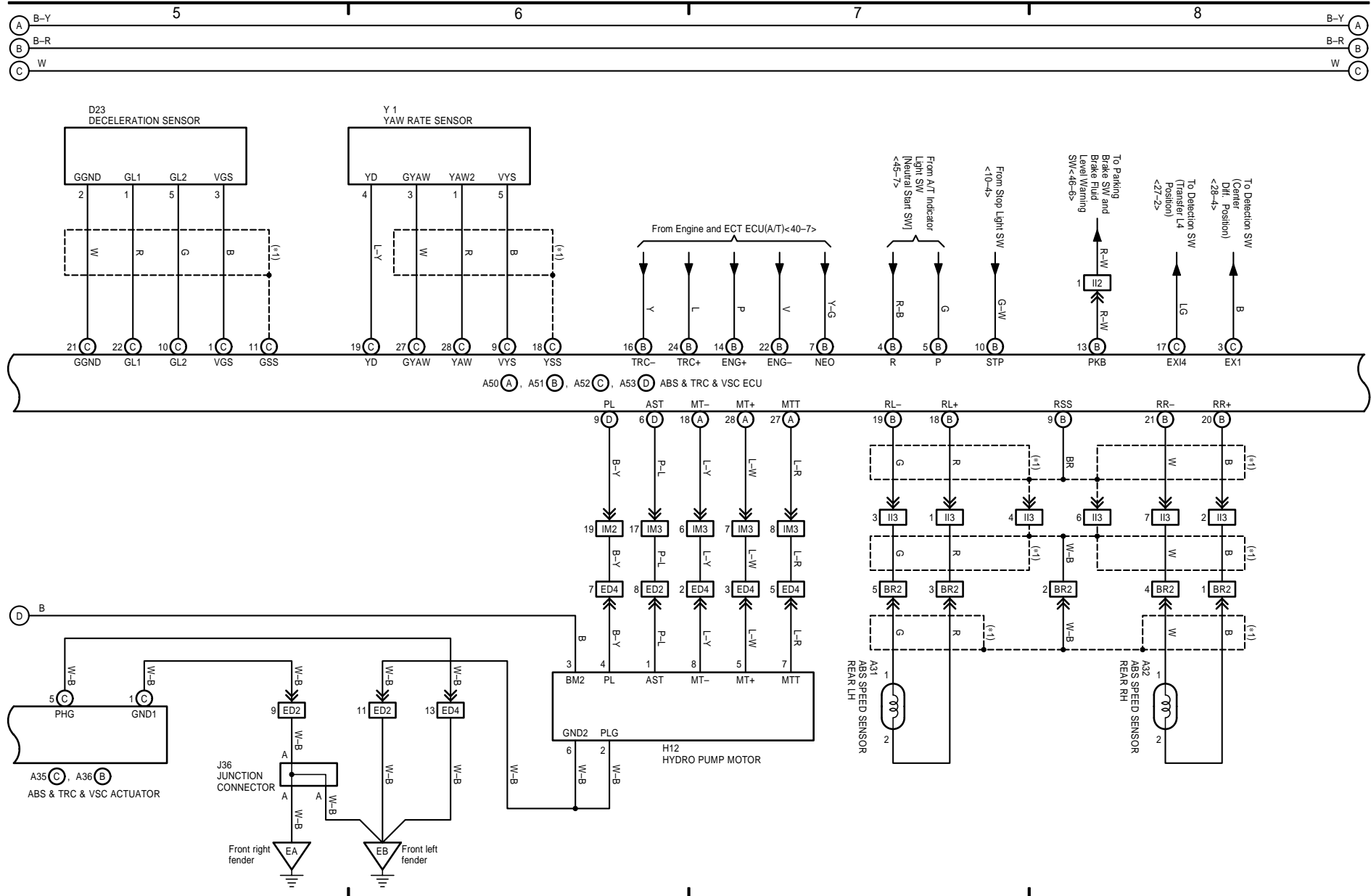

43 LAND CRUISER / LAND CRUISER PRADO (RHD) (Cont' d)

VSC (1KD-FTV)

* 1 : Shielded

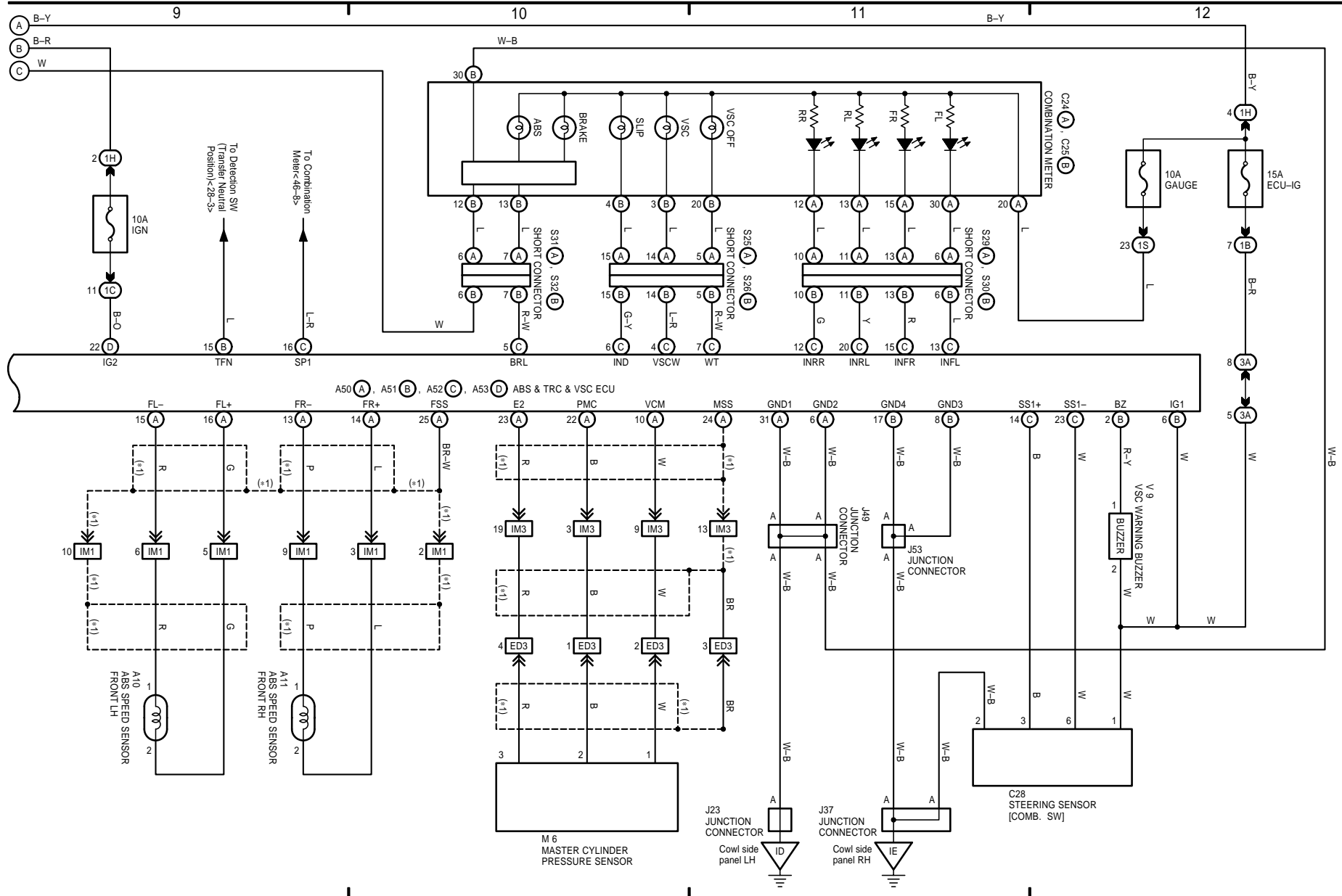

44 LAND CRUISER / LAND CRUISER PRADO (RHD)

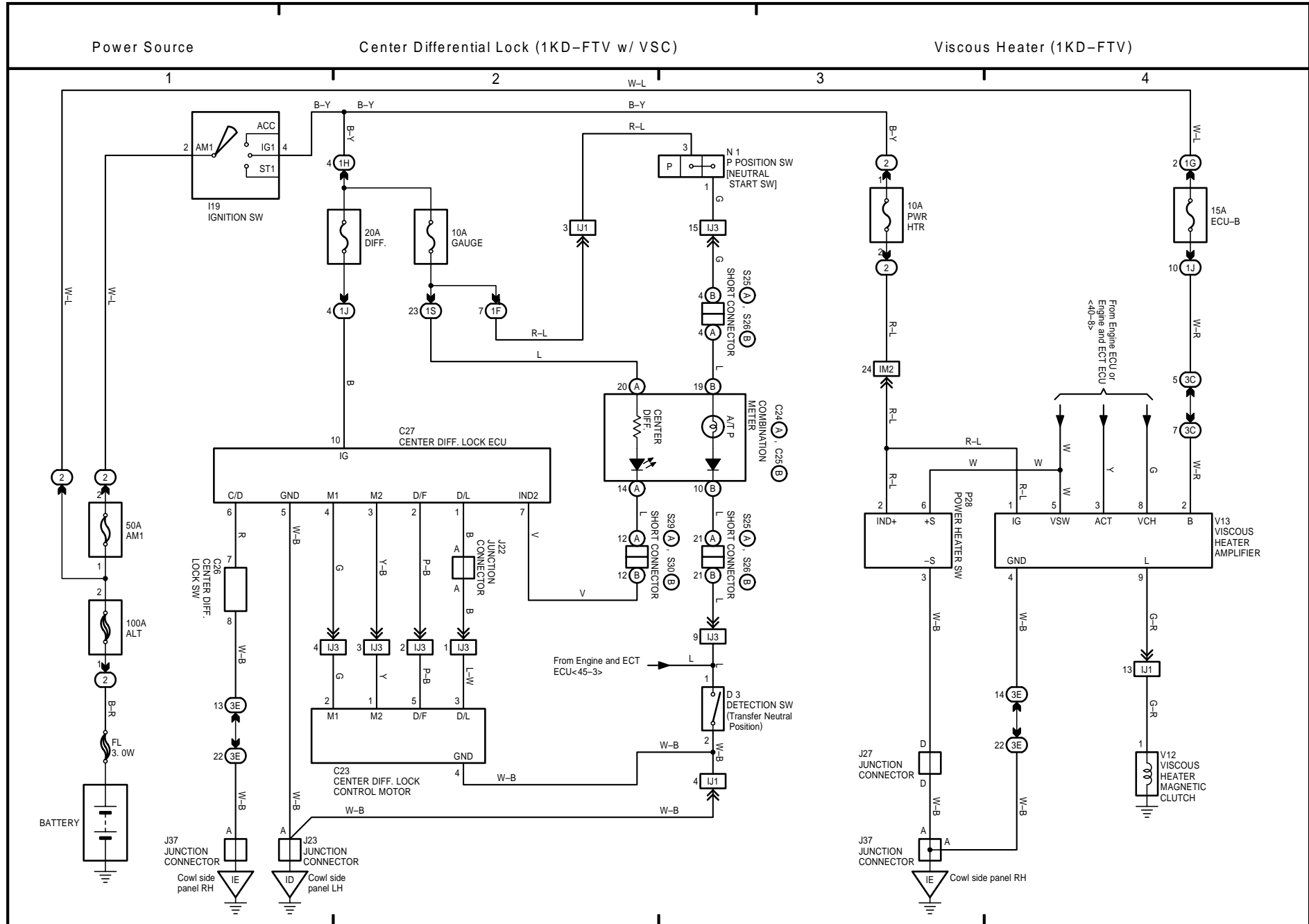

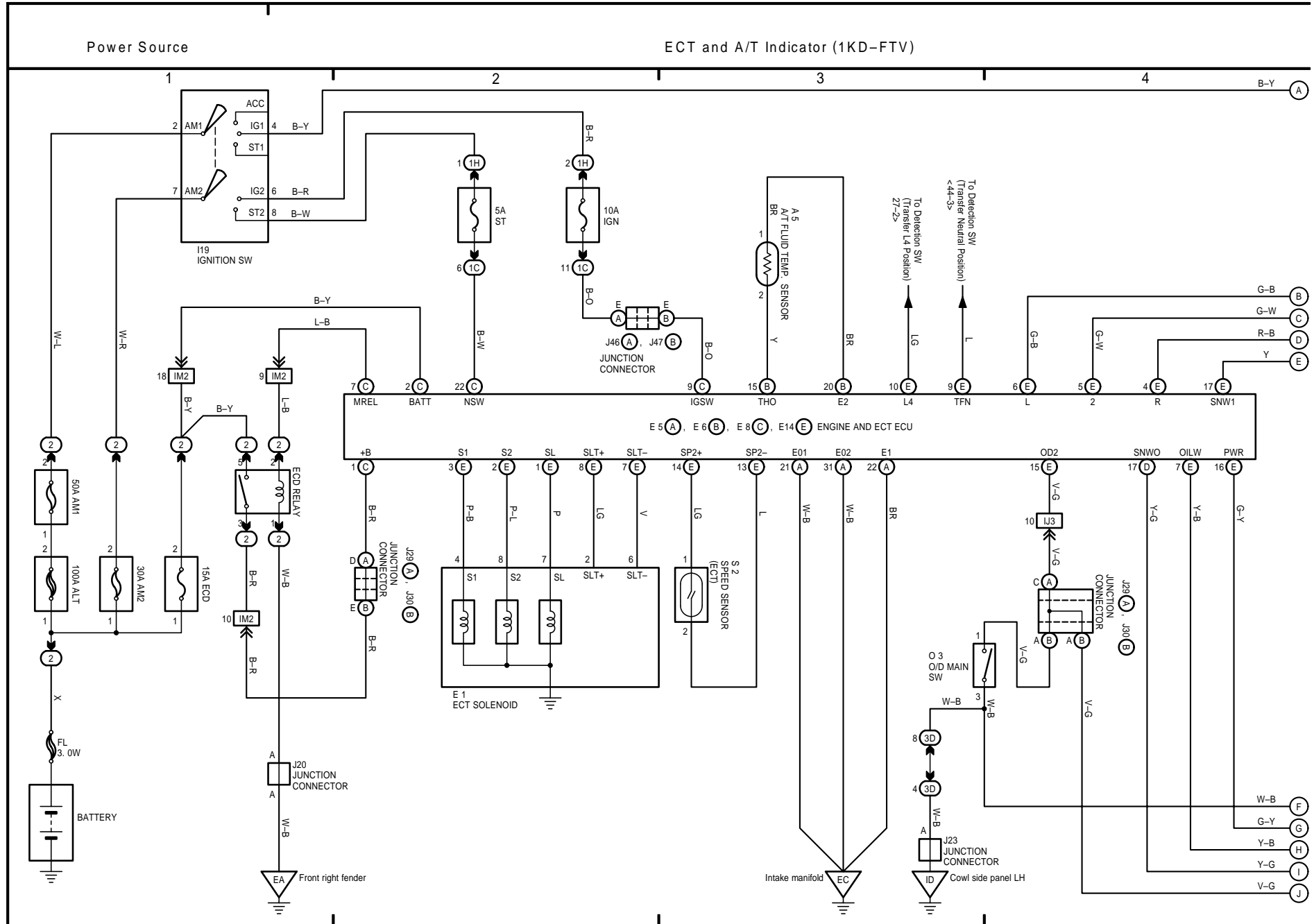

45 LAND CRUISER / LAND CRUISER PRADO (RHD) (Cont' d)

ECT and A/T Indicator (1KD-FTV)

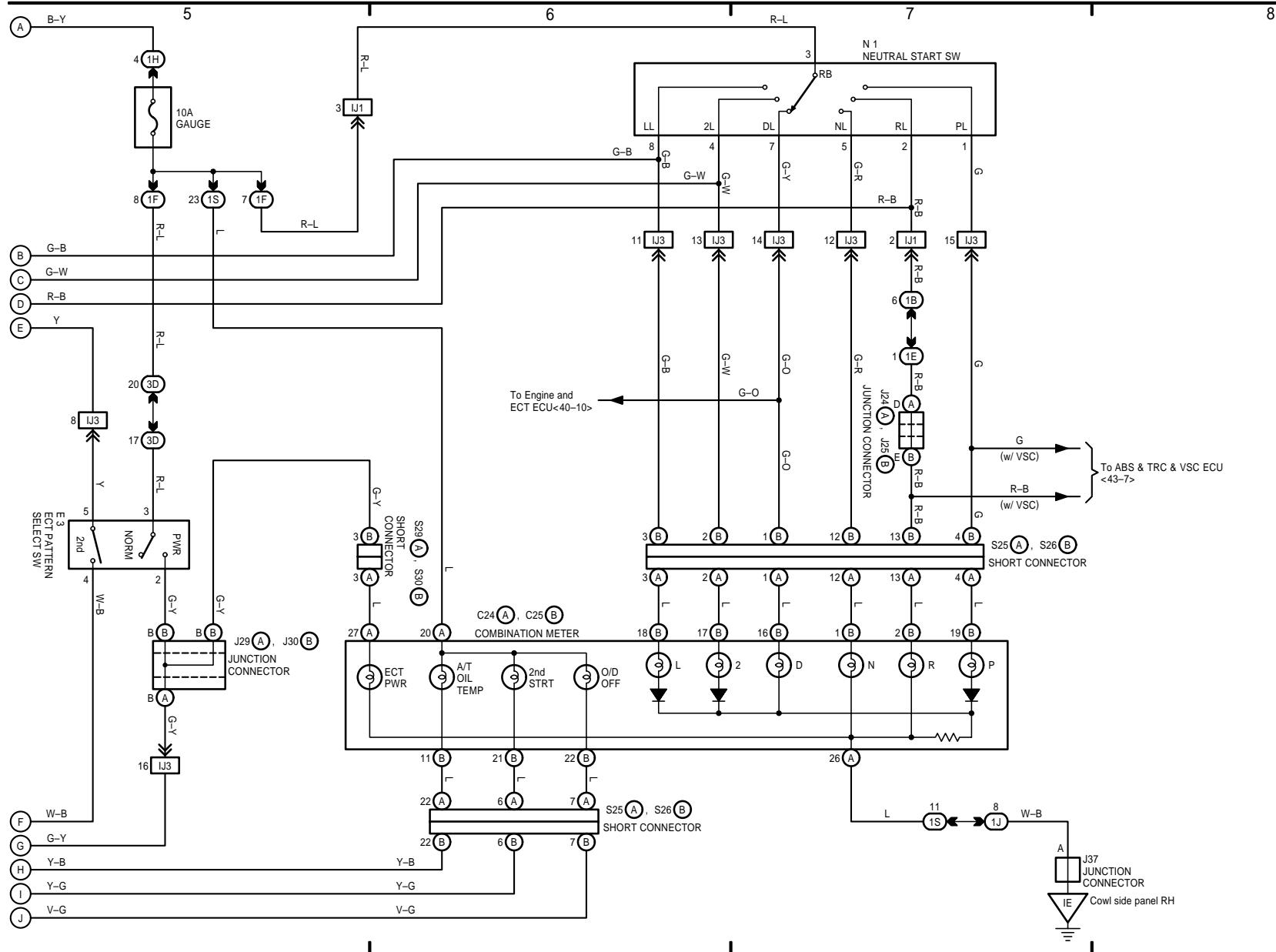

Air Conditioner (Automatic 1KD-FTV)

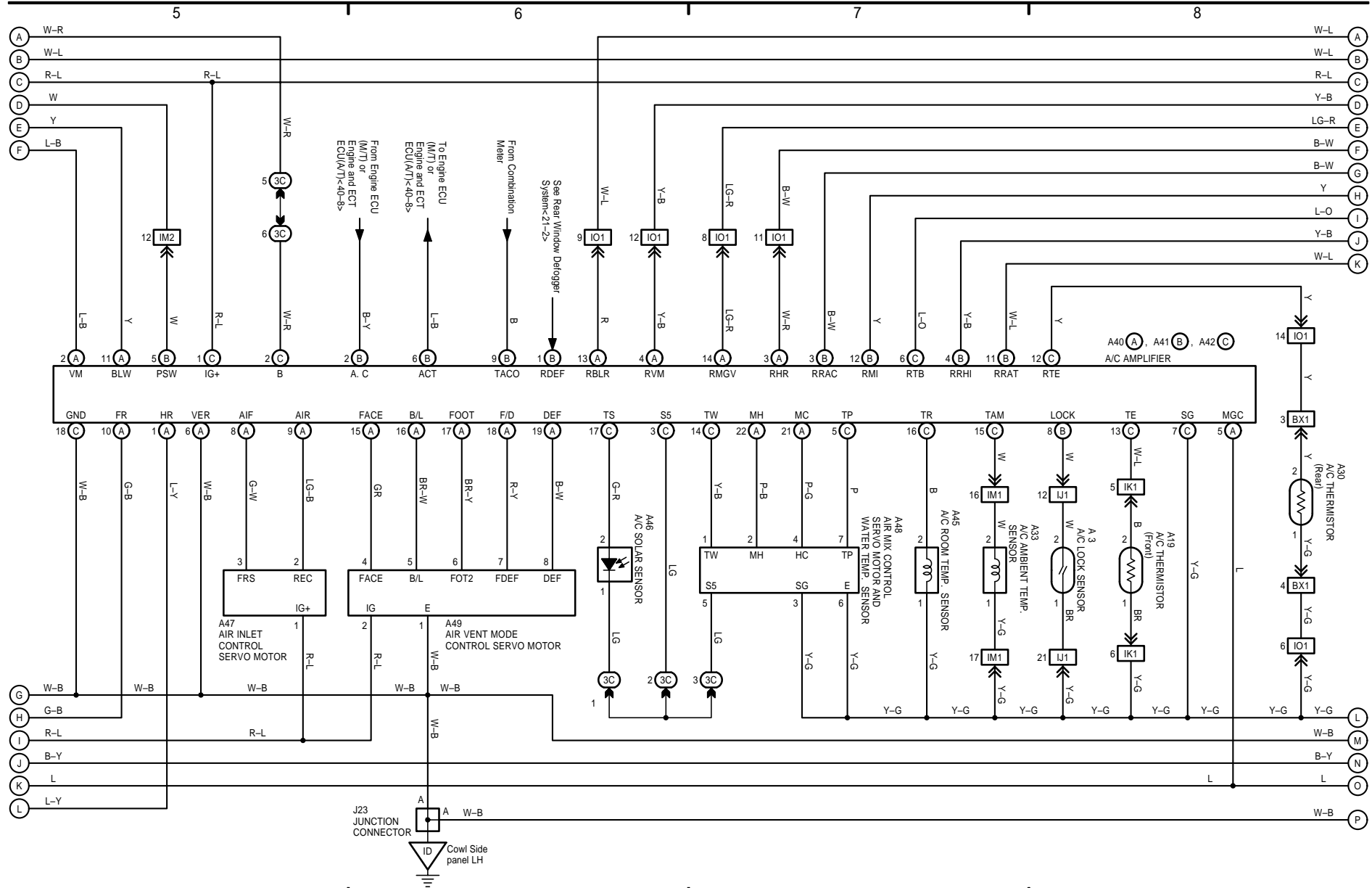

Air Conditioner (Automatic 1KD-FTV)

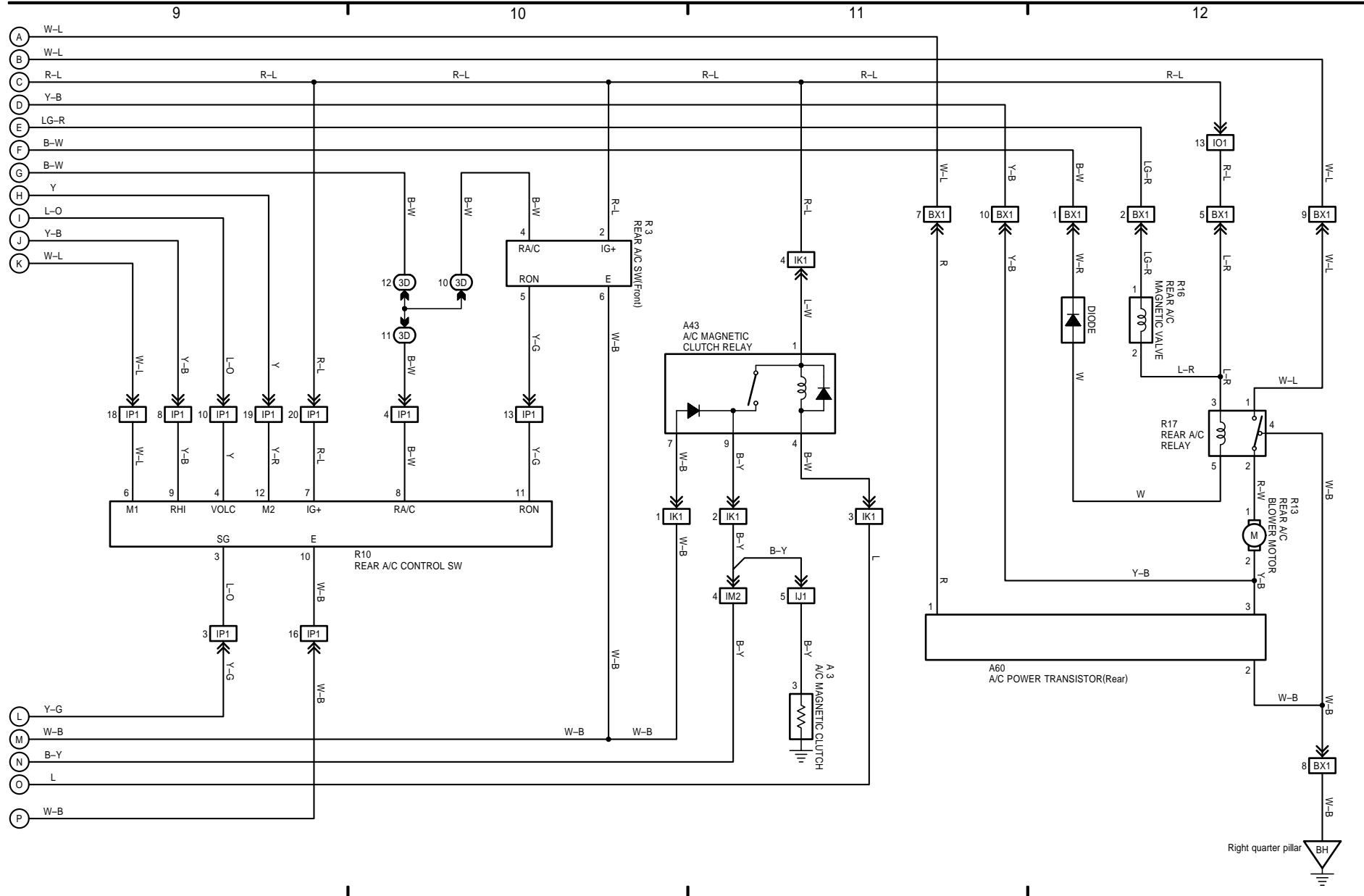

LAND CRUISER / LAND CRUISER PRADO

Connector Joining Wire Harness and Wire Harness

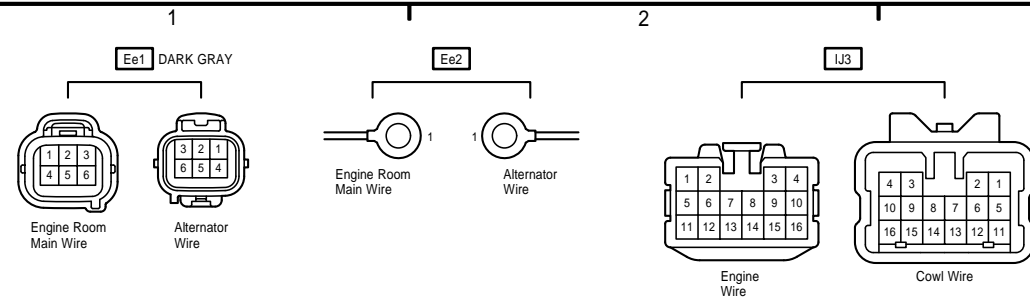

Connector List

1

2

3

4

A 1 BLACK



A 2 GRAY



A 3 GRAY



A 4 DARK GRAY



A 5



A10 GRAY



A11 GRAY



A13 BLACK



A14 BLACK



A15



A18 BLACK



A19



A23



A25 YELLOW



A26 YELLOW



A27 BLACK



A29 BLACK

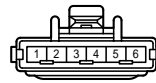

A30



A31 GRAY



A32 GRAY



A33 BLACK



A35 BLACK

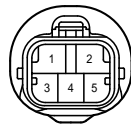

A36 GRAY



A40 ORANGE



A41 ORANGE

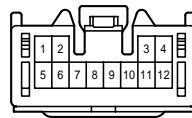

A42 ORANGE

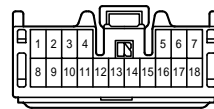

A44 BLACK



A45



A46 BLACK



(LHD) A47

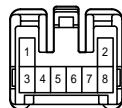

(RHD) A47



A48 GRAY

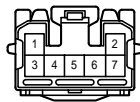

A49

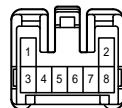

A50

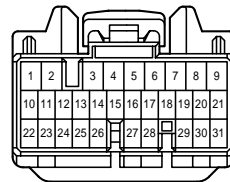

A51 BLACK

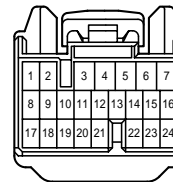

A52

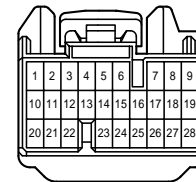

A53 BLACK



A58 BLACK



A60



B 2 GRAY



(LHD) B 3 BLACK



(RHD) B 3 GRAY



(LHD) B 4 BLACK

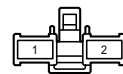

(RHD) B 4 BLACK



B 6

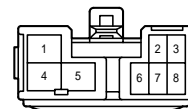

B11 GRAY



C 1 BLACK



Connector List

1

2

3

4

C 3 BLACK

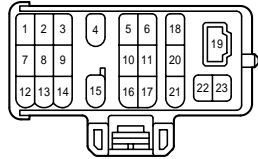

C 4 GRAY



C 7 GRAY



C 9 GRAY

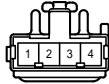

C 17 BLACK



C 18



C 20 YELLOW

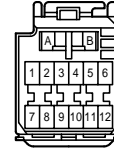

C 21 YELLOW

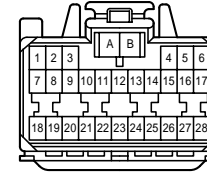

C 22 YELLOW

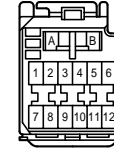

C 23 BLACK



C 24 BLUE

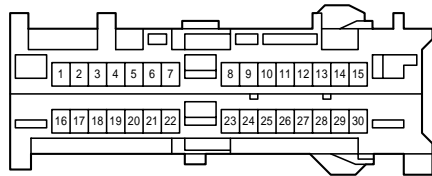

C 25

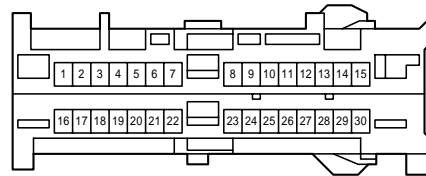

C 26 BLACK



C 27



C 28



D 3 GRAY

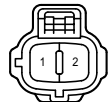

D 22 BLACK

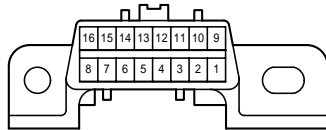

D 23 BLACK



E 1 GRAY



E 2



E 3 BLACK

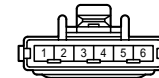

(1KD-FTV) E 5

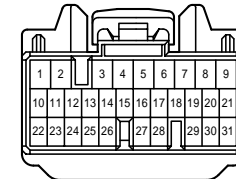

(3RZ-FE) E 5

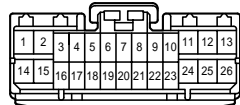

(1KD-FTV) E 6

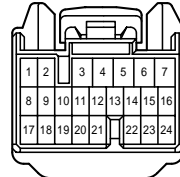

(3RZ-FE) E 6

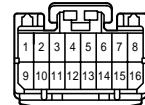

E 7

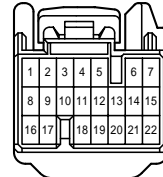

(1KD-FTV) E 8

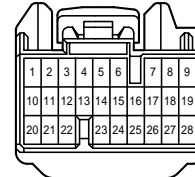

(3RZ-FE) E 8

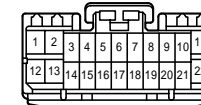

E 10



E 11 BLACK



Connector List

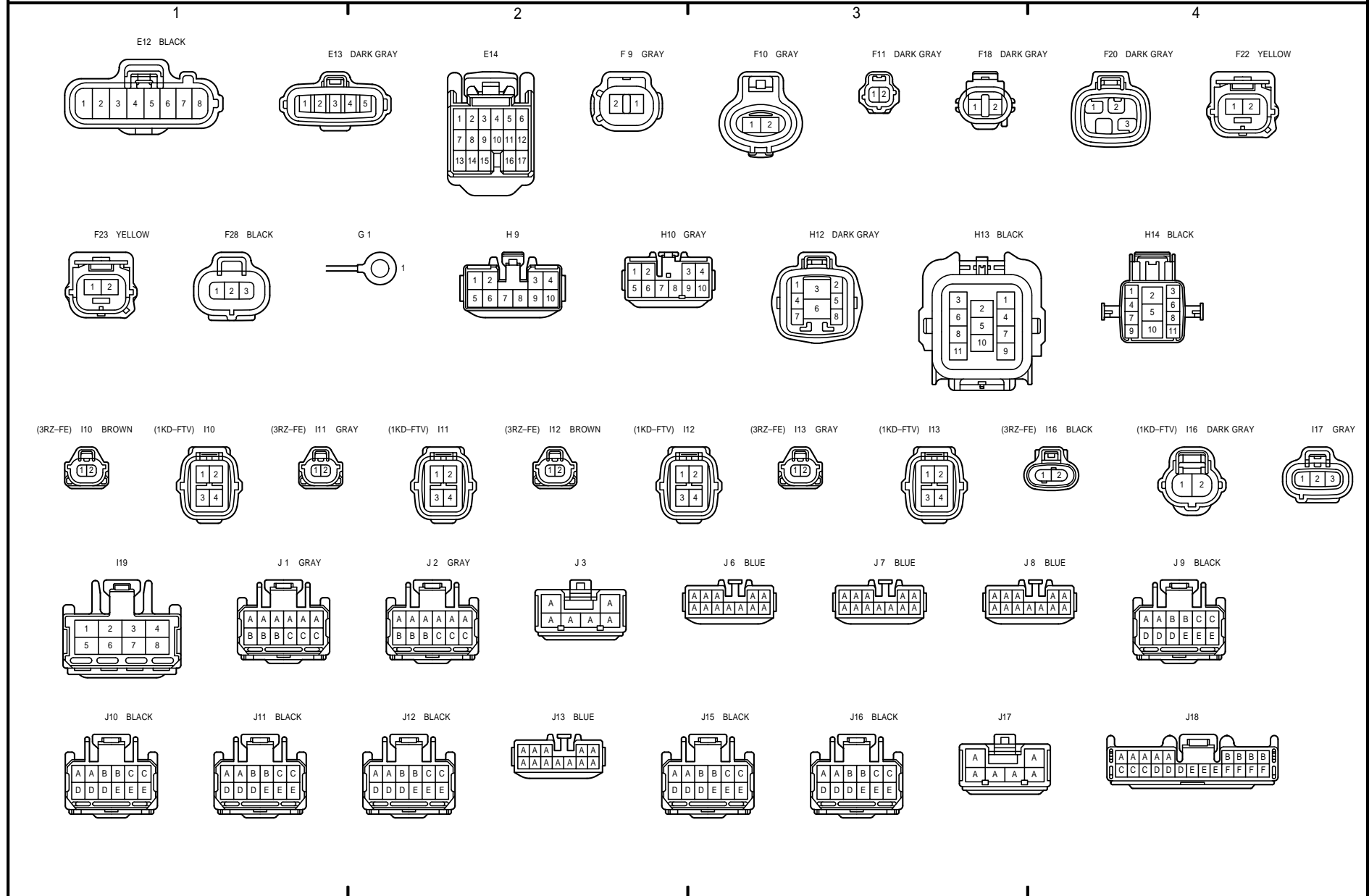

LAND CRUISER / LAND CRUISER PRADO

Connector List

1

2

3

4

J20 GRAY

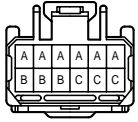

J21 GRAY

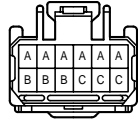

J22

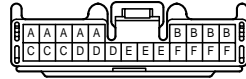

J23

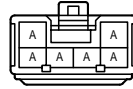

J24 BLACK

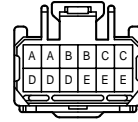

J25 BLACK

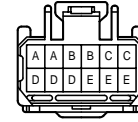

J26 BLACK

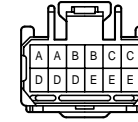

J27 BLACK

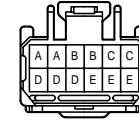

J29 BLACK

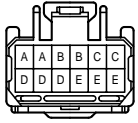

J30 BLACK

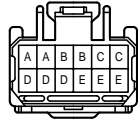

J31 BLUE



J32 BLUE



J36 BLUE



J37

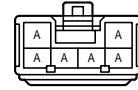

J39 BLUE



J41

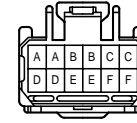

J42

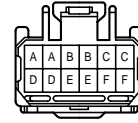

J46

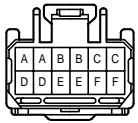

J47

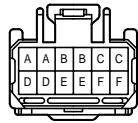

J49 BLUE



J50 GRAY



J51 BLACK

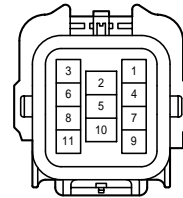

J52 GRAY



J53 BLACK



K1 DARK GRAY



M2 BLACK



M6 GRAY



N1 GRAY

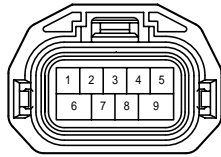

O1 GRAY



O3 BLUE



P4 BLACK



P24 YELLOW



P25 YELLOW



P28 BLACK

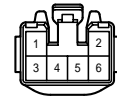

R1 BLUE

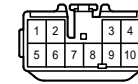

R2 BLUE



R3 BLACK



R5 BLACK



R6 BLACK



R7 BROWN



R9 BLUE



R10

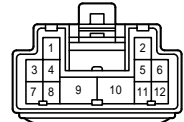

R12 BLACK



R13 BLACK



R16 BLACK



R17



S1 BLACK



Connector List

1

2

3

4

S 2 BLACK

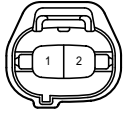

S 3 BLACK



S 4



S 5 BLUE



S 6



S 7 YELLOW

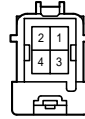

S 8 YELLOW



S 9 BROWN

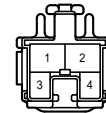

S 13

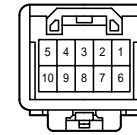

S 14

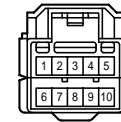

S 15

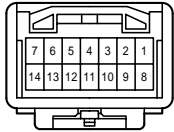

S 16

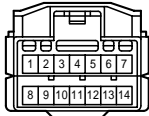

S 17

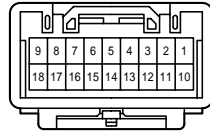

S 18

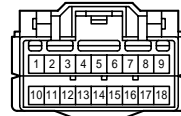

S 19

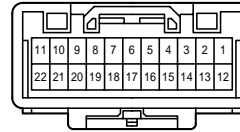

S 20

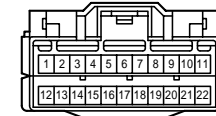

S 21

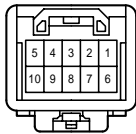

S 22

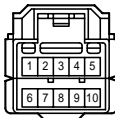

S 23

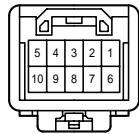

S 24

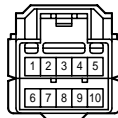

S 25

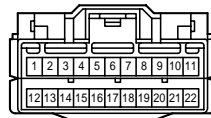

S 26

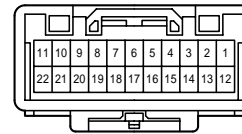

S 27

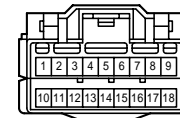

S 28

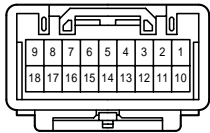

S 29

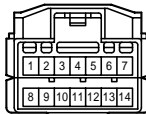

S 30

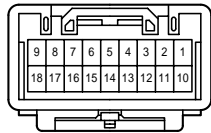

S 31



S 32

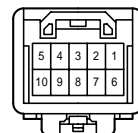

S 34 BLACK



S 35 BROWN



S 36 BLACK



T 1 BLACK



T 3 BLACK



T 4

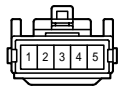

T 5

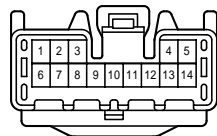

T 7 BLACK



T 8 GRAY

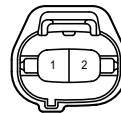

T 11 GRAY



U 1



V 1 BLACK



V 3 BROWN



V 8 BLACK



LAND CRUISER / LAND CRUISER PRADO

Connector List

1

V 9 BLACK



V12 GRAY



V13 BLACK

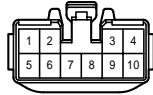

2

V14 BLUE

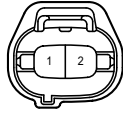

V15 BROWN



3

W 1 GRAY



W 2 DARK GRAY



4

Y 1 BLACK

