

# TRANSMISSION SERVICING - AT

## 1994 Toyota Paseo

1994 TRANSMISSION SERVICING  
Toyota Automatic Transmission

Paseo

### LUBRICATION

#### SERVICE INTERVALS

Inspect fluid level every 15,000 miles. Under severe operating conditions, change ATF and filter every 15,000 miles or 24 months.

#### CHECKING FLUID LEVEL

Transmission

Check fluid with vehicle on level surface and at normal operating temperature. With engine idling, shift each gear from "P" through "L" and back to "P". Fluid level should be in HOT range marked on dipstick. DO NOT overfill.

NOTE: If vehicle has been operated in heavy traffic, pulling a trailer or at high speeds in hot weather, wait 30 minutes before checking fluid level.

Differential

Remove filler plug. Fluid should be level with bottom edge of filler plug hole. If fluid is level with opening, install fill plug. If fluid is low, fill until fluid is level with fill plug opening. On FWD models, see DRAINING & REFILLING.

#### RECOMMENDED FLUID

All transmissions use Dexron-II automatic transmission fluid. See TRANSMISSION REFILL CAPACITIES table.

#### TRANSMISSION REFILL CAPACITIES TABLE

Application (1)	Refill Qts. (L) (2)	Dry-Fill Qts. (L)
Paseo (A244E) .....	3.3 (3.1) .....	7.6 (7.2)

(1) - Use Dexron-II ATF.

(2) - Fluid capacity may vary if pan and filter are removed.

#### DIFFERENTIAL REFILL CAPACITIES TABLE

Application	Qts. (L)
Paseo .....	(1)

(1) - Transmission and differential are one unit.

#### DRAINING & REFILLING

Transmission

1) Remove engine undercover if necessary. Remove drain plug and drain fluid. If replacing transmission filter, remove oil pan. Thoroughly clean transmission oil pan. Install filter and pan with new gasket.

CAUTION: When removing transmission filter, note different size bolt lengths for reassembly reference.

2) Replace pan drain plug and fill transmission with approximate amount of ATF fluid. See TRANSMISSION REFILL CAPACITIES table. Start engine and shift through all gears. Shift into "P" and check fluid level. Add fluid as necessary. DO NOT overfill.

#### Differential

Some FWD models have separate drain plugs for transmission and differential. Both transmission and differential plugs must be removed to drain all fluid from both units. Transaxle is filled through dipstick tube, and differential is filled through a separate fill plug. See Fig. 1. Fill differential until fluid is level with fill hole.

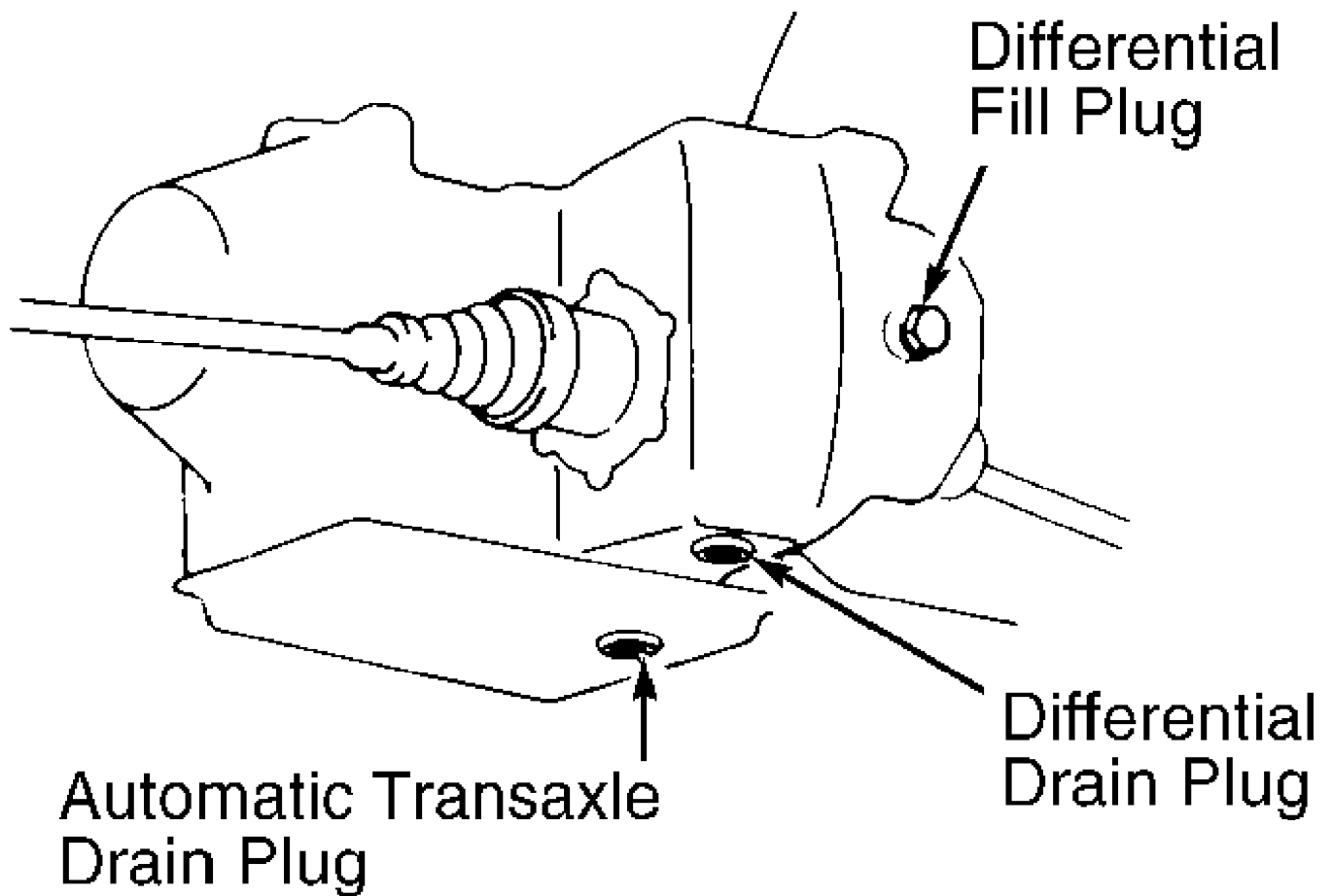

82877

Fig. 1: Servicing Differential On Integral-Type Transaxle  
Courtesy of Toyota Motor Sales, U.S.A., Inc.

## SHIFT CABLE

1) Loosen swivel nut on manual shift lever. Push manual shift lever fully toward right side of vehicle.

2) Return lever 2 notches to Neutral position. Ensure shift lever is in "N". While holding lever lightly toward "R" range side, tighten swivel nut to 61 INCH lbs. (6 N.m). See Fig. 2.

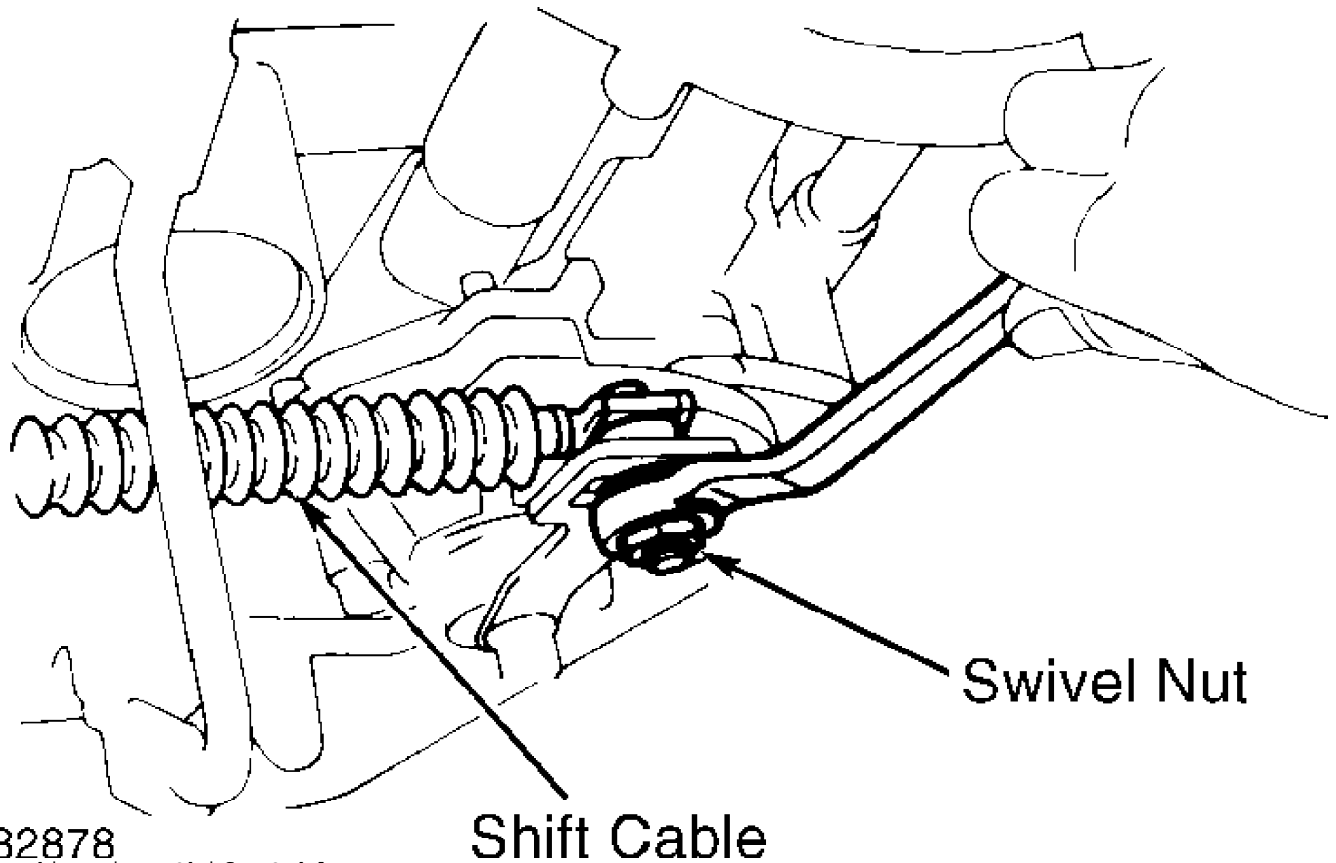

Fig. 2: Adjusting Shift Cable  
Courtesy of Toyota Motor Sales, U.S.A., Inc.

## THROTTLE CABLE

1) Release accelerator pedal and ensure throttle valve is fully closed. Ensure throttle cable is installed correctly, and is not bent and does not bind. Check that inner cable is not slack.

2) With throttle valve fully closed, adjust cable housing so distance between end of boot and stopper on cable is .04" (1 mm). See Fig. 3. Tighten adjusting nut and recheck adjustment.

3) For new throttle cables, stopper will not be in place. Bend new cable so there is a 7.87" (200 mm) radius and pull inner cable slightly until resistance is felt. Stake new stopper .031-.059" (0.8-1.5 mm) from end of outer cable.

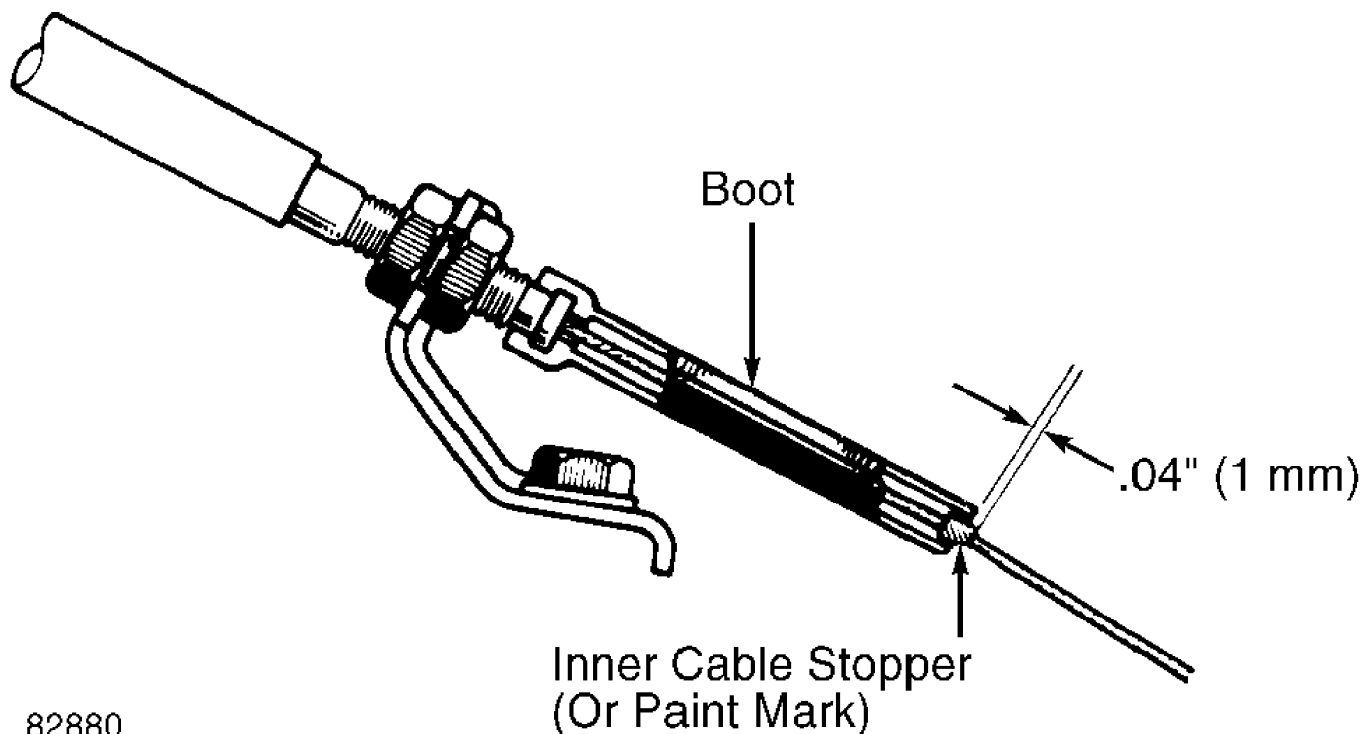

82880

Fig. 3: Adjusting Throttle Cable  
 Courtesy of Toyota Motor Sales, U.S.A., Inc.

### NEUTRAL SAFETY SWITCH

Loosen neutral safety switch bolts. Position shift lever in "N". Align switch shaft groove to neutral basic line. See Fig. 4. Tighten adjusting bolt. Ensure vehicle will only start in "N" or "P" positions.

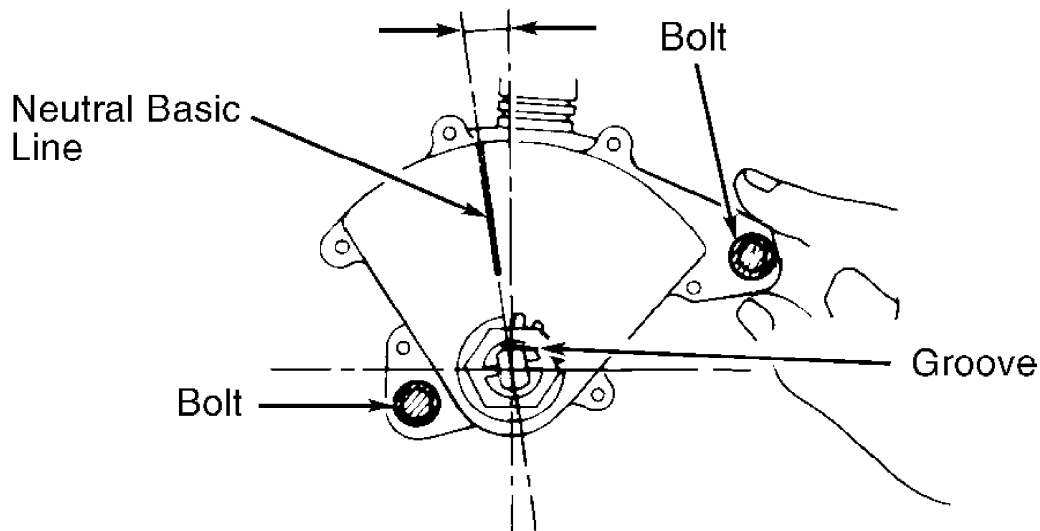

100116

Fig. 4: Adjusting FWD Neutral Safety Switch (RWD Adjustment Is Similar)  
 Courtesy of Toyota Motor Sales, U.S.A., Inc.

